

REVIEWER NOTES:

1. THIS PROJECT WILL UTILIZE PHASED CONSTRUCTION.
2. IT IS ANTICIPATED THAT CHANNEL RIGHTS WILL BE NECESSARY FOR THIS PROJECT. THE EXTENT OF RIGHTS REQUIRED WILL NOT BE KNOWN UNTIL FINAL DESIGN.
3. SIMPLIFIED PAVEMENT DESIGN HAS BEEN DONE FOR THIS PROJECT.
4. UNDERGROUND ELECTRIC LINES ARE BURIED ON THE NORTH AND SOUTH SIDE OF VT 117. VAOT OWNS THESE LINES.

TWO 12" DIAMETER UNDERGROUND SEWER LINES ARE ENCASED IN CONCRETE CROSS UNDER THE EXISTING CULVERT INLET (1.5' BELOW THE EXISTING CULVERT).

VERMONT GAS HAS A MAIN THAT CROSSES AT THE OUTLET (APPROXIMATELY 6'-8" BELOW THE STREAM BED).

ABOVE GROUND AND UNDERGROUND UTILITY RELOCATIONS ARE NOT REQUIRED.

5. TEMPORARY PRESTRESSED CONCRETE SLABS WERE CONSTRUCTED AS A PREVIOUS REPAIR. THE SLABS WILL BE REMOVED AS PART OF CONSTRUCTION.

# STATE OF VERMONT AGENCY OF TRANSPORTATION



## PROPOSED IMPROVEMENT BRIDGE PROJECT

TOWN OF ESSEX  
COUNTY OF CHITTENDEN

ROUTE NO : VT 117, PRINCIPAL ARTERIAL  
BRIDGE NO : 2

PROJECT LOCATION: PROJECT IS LOCATED ON THE EAST SIDE OF THE VT 117/VT 289 INTERSECTION (OVER ALDER BROOK).  
PROJECT DESCRIPTION: REPLACEMENT OF AN EXISTING 17'-2" WIDE X 11'-4" HIGH CGMP CGMPPA WITH A NEW ARCH STRUCTURE.

LENGTH OF STRUCTURE: 42.53 FEET  
LENGTH OF ROADWAY: 800.00 FEET  
LENGTH OF PROJECT: 600.00 FEET

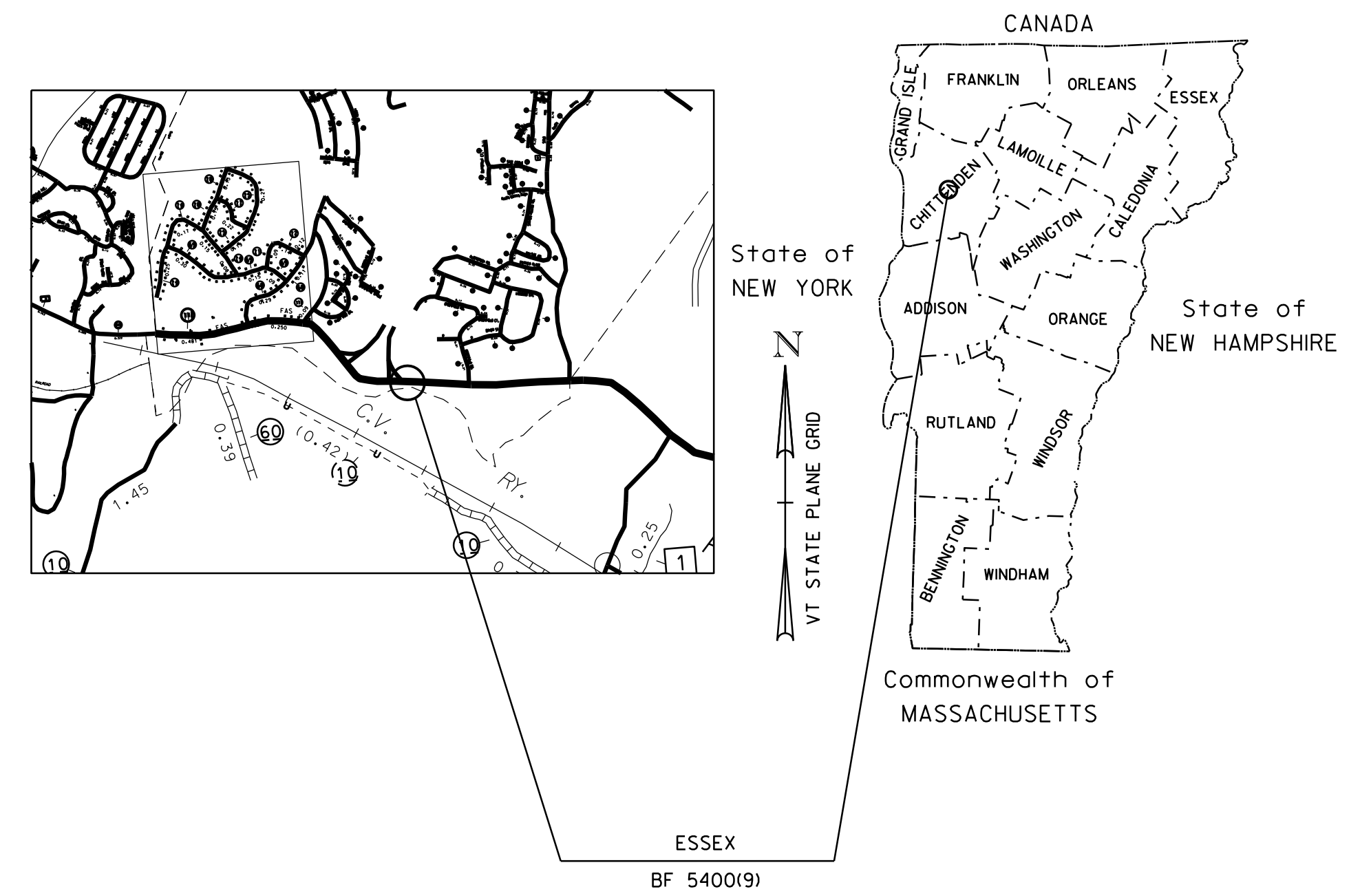

CONCEPTUAL PLANS  
07-AUG-2017

CONSTRUCTION IS TO BE CARRIED ON IN ACCORDANCE WITH THESE PLANS AND THE STANDARD SPECIFICATIONS FOR CONSTRUCTION DATED 2011, AS APPROVED BY THE FEDERAL HIGHWAY ADMINISTRATION ON JULY 20, 2011 FOR USE ON THIS PROJECT, INCLUDING ALL SUBSEQUENT REVISIONS AND SUCH REVISED SPECIFICATIONS AND SPECIAL PROVISIONS AS ARE INCORPORATED IN THESE PLANS.

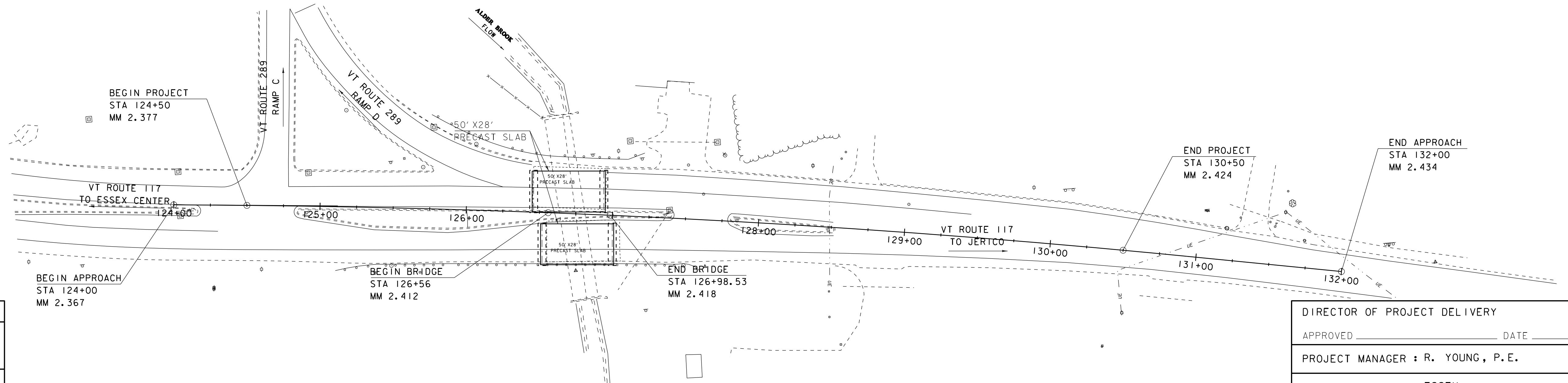

QUALITY ASSURANCE PROGRAM : LEVEL 2	
SURVEYED BY :	R. BULLOCK
SURVEYED DATE :	12/12/2013
DATUM	
VERTICAL	NAVD 88
HORIZONTAL	NAD 83 (2011)

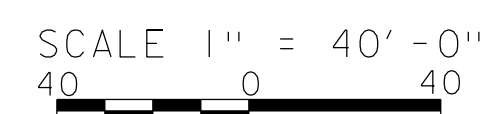

DIRECTOR OF PROJECT DELIVERY	
APPROVED _____	DATE _____
PROJECT MANAGER : R. YOUNG, P.E.	
PROJECT NAME :	ESSEX
PROJECT NUMBER :	BF 5400 (9)
SHEET 1 OF	SHEETS 27

INDEX OF SHEETS						FINAL HYDRAULIC REPORT																																																			
<b>PLAN SHEETS</b>						<b>STANDARDS LIST</b>																																																			
1	TITLE SHEET																																																								
2	PRELIMINARY INFORMATION SHEET																																																								
3	LEGEND SHEET																																																								
4	TYPICAL SECTIONS																																																								
5 - 6	LAYOUT SHEETS																																																								
7 - 8	ALIGNMENT SHEETS																																																								
9	MAINLINE PROFILE																																																								
10	RAMP PROFILE AND MATERIAL TRANSITION																																																								
11 - 12	UTILITY SHEETS																																																								
13 - 20	MAINLINE CROSS SECTIONS																																																								
21 - 24	CHANNEL CROSS SECTIONS																																																								
25 - 26	RESOURCE SITE PLANS																																																								
<b>STRUCTURES DETAIL SHEETS</b>						<b>FINAL HYDRAULIC REPORT</b>																																																			
SD-502.00	CONCRETE DETAILS AND NOTES			5/7/2010																																																					
						<b>TRAFFIC MAINTENANCE NOTES</b>																																																			
						1. MAINTAIN TRAFFIC ON AN OFF SITE DETOUR. 2. TRAFFIC SIGNALS ARE NOT NECESSARY. 3. SIDEWALKS ARE NOT NECESSARY																																																			
						<b>DESIGN VALUES</b>																																																			
						1. DESIGN LIVE LOAD HL-93 2. FUTURE PAVEMENT $d_p$ : 3.0 INCH 3. DESIGN SPAN $L$ : 38.00 FT  4. MIN. MID-SPAN POS. CAMBER @ RELEASE (PRESTRESSED UNITS) $\Delta$ : --- 5. PRESTRESSING STRAND (0.60 INCH DIAMETER - LOW RELAX) $f_y$ : --- 6. PRESTRESSED CONCRETE STRENGTH $f'_c$ : --- 7. PRESTRESSED CONCRETE RELEASE STRENGTH $f'_{ci}$ : --- 8. CONCRETE, HIGH PERFORMANCE CLASS AA $f'_c$ : --- 9. CONCRETE, HIGH PERFORMANCE CLASS A $f'_c$ : 4.0 KSI 10. CONCRETE, HIGH PERFORMANCE CLASS B $f'_c$ : 3.5 KSI 11. CONCRETE, CLASS C $f'_c$ : 3.0 KSI 12. REINFORCING STEEL $f_y$ : 60 KSI 13. STRUCTURAL STEEL AASHTO M270 $f_y$ : ---  14. NOMINAL BEARING RESISTANCE OF SOIL $q_n$ : 8.9 KSF 15. SOIL BEARING RESISTANCE FACTOR (REFER TO AASHTO LRFD) $\phi$ : 0.45 16. NOMINAL BEARING RESISTANCE OF ROCK $q_n$ : 70 KSF 17. ROCK BEARING RESISTANCE FACTOR (REFER TO AASHTO LRFD) $\phi$ : 0.45  18. PILE RESISTANCE FACTOR $\phi$ : --- 19. LATERAL PILE DEFLECTION $\Delta$ : --- 20. BASIC WIND SPEED $V_{3s}$ : --- 21. MINIMUM GROUND SNOW LOAD $p_g$ : --- 22. SEISMIC DATA $PGA$ : 0 $S_s$ : --- $S_f$ : ---  23. --- 24. --- 25. --- 26. ---																																																			
						<b>LRFR LOAD RATING FACTORS</b>																																																			
						<table border="1" style="width: 100%; border-collapse: collapse;"> <thead> <tr> <th rowspan="2">LOADING LEVELS</th> <th colspan="6">TRUCK</th> </tr> <tr> <th>H-20</th> <th>HL-93</th> <th>3S2</th> <th>6 AXLE</th> <th>3A. STR.</th> <th>4A. STR.</th> <th>5A. SEMI</th> </tr> </thead> <tbody> <tr> <td>TONNAGE</td> <td>20</td> <td>36</td> <td>36</td> <td>66</td> <td>30</td> <td>34.5</td> <td>38</td> </tr> <tr> <td>INVENTORY</td> <td></td> <td></td> <td></td> <td></td> <td></td> <td></td> <td></td> </tr> <tr> <td>POSTING</td> <td></td> <td></td> <td></td> <td></td> <td></td> <td></td> <td></td> </tr> <tr> <td>OPERATING</td> <td></td> <td></td> <td></td> <td></td> <td></td> <td></td> <td></td> </tr> </tbody> </table>						LOADING LEVELS	TRUCK						H-20	HL-93	3S2	6 AXLE	3A. STR.	4A. STR.	5A. SEMI	TONNAGE	20	36	36	66	30	34.5	38	INVENTORY								POSTING								OPERATING							
LOADING LEVELS	TRUCK																																																								
	H-20	HL-93	3S2	6 AXLE	3A. STR.	4A. STR.	5A. SEMI																																																		
TONNAGE	20	36	36	66	30	34.5	38																																																		
INVENTORY																																																									
POSTING																																																									
OPERATING																																																									
						<table border="1" style="width: 100%; border-collapse: collapse;"> <thead> <tr> <th colspan="3">AS BUILT "REBAR" DETAIL</th> </tr> <tr> <th>LEVEL I</th> <th>LEVEL II</th> <th>LEVEL III</th> </tr> </thead> <tbody> <tr> <td>TYPE:</td> <td>TYPE:</td> <td>TYPE:</td> </tr> <tr> <td>GRADE:</td> <td>GRADE:</td> <td>GRADE:</td> </tr> </tbody> </table>						AS BUILT "REBAR" DETAIL			LEVEL I	LEVEL II	LEVEL III	TYPE:	TYPE:	TYPE:	GRADE:	GRADE:	GRADE:																																		
AS BUILT "REBAR" DETAIL																																																									
LEVEL I	LEVEL II	LEVEL III																																																							
TYPE:	TYPE:	TYPE:																																																							
GRADE:	GRADE:	GRADE:																																																							
						<b>FRAME DESIGN CRITERIA</b>																																																			
						1. PROPOSED FRAME IS A PRECAST CONCRETE STRUCTURE (33'-0" X 36'-5"). 2. FRAME ENDS ARE PLUMB.																																																			
<b>TRAFFIC DATA</b>																																																									
YEAR	ADT	DHV	% D	% T	ADTT	20 year ESAL for flexible pavement from 2017 to 2037 : 421000																																																			
2017	1400	160	56	3.7	85	40 year ESAL for flexible pavement from 2017 to 2057 : 908000																																																			
2037	1400	160	56	5.1	120	Design Speed : 35 mph																																																			
						PROJECT NAME: <b>POULTNEY</b> PROJECT NUMBER: <b>BF 0138(12)</b>  FILE NAME: s13j276pi.dgn PLOT DATE: 7/20/2017 PROJECT LEADER: R. YOUNG DRAWN BY: G. DARGAN DESIGNED BY: G. DARGAN CHECKED BY: G. LAROCHE <b>PRELIMINARY INFORMATION SHEET 1</b> SHEET 2 OF 26																																																			

**GENERAL INFORMATION**

**SYMBOLGY LEGEND NOTE**

THE SYMBOLGY ON THIS SHEET IS INTENDED TO COVER STANDARD CONVENTIONAL SYMBOLGY. THE SYMBOLGY IS USED FOR EXISTING & PROPOSED FEATURES WITH HEAVIER LINEWEIGHT, IN COMBINATION WITH PROJECT ANNOTATION, AS NOTED ON PROJECT PLAN SHEETS. THIS LEGEND SHEET COVERS THE BASICS. SYMBOLGY ON PLANS MAY VARY, PLAN ANNOTATIONS AND NOTES SHOULD BE USED TO CLARIFY AS NEEDED.

**R. O. W. ABBREVIATIONS (CODES) & SYMBOLS**

POINT CODE	DESCRIPTION
CH	CHANNEL EASEMENT
CONST	CONSTRUCTION EASEMENT
CUL	CULVERT EASEMENT
D&C	DISCONNECT & CONNECT
DIT	DITCH EASEMENT
DR	DRAINAGE EASEMENT
DRIVE	DRIVEWAY EASEMENT
EC	EROSION CONTROL
HWY	HIGHWAY EASEMENT
I&M	INSTALL & MAINTAIN EASEMENT
LAND	LANDSCAPE EASEMENT
R&RES	REMOVE & RESET
R&REP	REMOVE & REPLACE
SR	SLOPE RIGHT
UE	UTILITY EASEMENT
(P)	PERMANENT EASEMENT
(T)	TEMPORARY EASEMENT
■	BNDNS BOUND SET
□	BNDNS BOUND TO BE SET
⊙	IPNF IRON PIN FOUND
●	IPNS IRON PIN TO BE SET
⊠	CALC EXISTING ROW POINT
○	PROW PROPOSED ROW POINT
[LENGTH]	LENGTH CARRIED ON NEXT SHEET

**COMMON TOPOGRAPHIC POINT SYMBOLS**

POINT CODE	DESCRIPTION
⊕	APL BOUND APPARENT LOCATION
□	BM BENCHMARK
□	BND BOUND
⊞	CB CATCH BASIN
⊞	COMB COMBINATION POLE
⊞	DITHR DROP INLET THROATED DNC
⊞	EL ELECTRIC POWER POLE
○	FPOLE FLAGPOLE
○	GASFIL GAS FILLER
○	GP GUIDE POST
×	GSO GAS SHUT OFF
○	GUY GUY POLE
○	GUYW GUY WIRE
×	GV GATE VALVE
⊞	H TREE HARDWOOD
△	HCTRL CONTROL HORIZONTAL
△	HVCTRL CONTROL HORIZ. & VERTICAL
◇	HYD HYDRANT
●	IP IRON PIN
●	IPIPE IRON PIPE
⊞	LI LIGHT - STREET OR YARD
⊞	MB MAILBOX
○	MH MANHOLE (MH)
●	MM MILE MARKER
●	PM PARKING METER
●	PMK PROJECT MARKER
○	POST POST STONE/WOOD
⊞	RRSIG RAILROAD SIGNAL
⊞	RRSL RAILROAD SWITCH LEVER
⊞	S TREE SOFTWOOD
⊞	SAT SATELLITE DISH
⊞	SHRUB SHRUB
⊞	SIGN SIGN
⊞	STUMP STUMP
⊞	TEL TELEPHONE POLE
○	TIE TIE
⊞	TSIGN SIGN W/DOUBLE POST
⊞	VCTRL CONTROL VERTICAL
○	WELL WELL
×	WSO WATER SHUT OFF

THESE ARE COMMON VAOT SURVEY POINT SYMBOLS FOR EXISTING FEATURES, ALSO USED FOR PROPOSED FEATURES WITH HEAVIER LINEWEIGHT, IN COMBINATION WITH PROPOSED ANNOTATION.

**PROPOSED GEOMETRY CODES**

CODE	DESCRIPTION
PC	POINT OF CURVATURE
PI	POINT OF INTERSECTION
CC	CENTER OF CURVE
PT	POINT OF TANGENCY
PCC	POINT OF COMPOUND CURVE
PRC	POINT OF REVERSE CURVE
POB	POINT OF BEGINNING
POE	POINT OF ENDING
STA	STATION PREFIX
AH	AHEAD STATION SUFFIX
BK	BACK STATION SUFFIX
D	CURVE DEGREE OF (100FT)
R	CURVE RADUIS OF
T	CURVE TANGENT LENGTH
L	CURVE LENGTH OF
E	CURVE EXTERNAL DISTANCE

**UTILITY SYMBOLGY**

**UNDERGROUND UTILITIES**

— UT —	UTILITY (GENERIC-UNKNOWN)
— UE —	TELEPHONE
— UE —	ELECTRIC
— UC —	CABLE (TV)
— UEC —	ELECTRIC+CABLE
— UET —	ELECTRIC+TELEPHONE
— UCT —	CABLE+TELEPHONE
— UECT —	ELECTRIC+CABLE+TELEP.
— G —	GAS LINE
— W —	WATER LINE
— S —	SANITARY SEWER (SEPTIC)

**ABOVE GROUND UTILITIES (AERIAL)**

— T —	UTILITY (GENERIC-UNKNOWN)
— E —	TELEPHONE
— C —	CABLE (TV)
— EC —	ELECTRIC+CABLE
— ET —	ELECTRIC+TELEPHONE
— AER E&T —	ELECTRIC+TELEPHONE
— CT —	CABLE+TELEPHONE
— ECT —	ELECTRIC+CABLE+TELEP.
—	UTILITY POLE GUY WIRE

**PROJECT CONSTRUCTION SYMBOLGY**

**PROJECT DESIGN & LAYOUT SYMBOLGY**

— CZ —	CLEAR ZONE
—	PLAN LAYOUT MATCHLINE

**PROJECT CONSTRUCTION FEATURES**

—	TOP OF CUT SLOPE
—	TOE OF FILL SLOPE
—	STONE FILL
—	BOTTOM OF DITCH
—	CULVERT PROPOSED
—	STRUCTURE SUBSURFACE
PDF	PROJECT DEMARCATION FENCE
BF	BARRIER FENCE
—	TREE PROTECTION ZONE (TPZ)
—	STRIPING LINE REMOVAL
—	SHEET PILES

**CONVENTIONAL BOUNDARY SYMBOLGY**

**BOUNDARY LINES**

—	TOWN BOUNDARY LINE
—	COUNTY BOUNDARY LINE
—	STATE BOUNDARY LINE
—	PROPOSED STATE R.O.W. (LIMITED ACCESS)
—	PROPOSED STATE R.O.W.
—	STATE ROW (LIMITED ACCESS)
—	STATE ROW
—	TOWN ROW
—	PERMANENT EASEMENT LINE (P)
—	TEMPORARY EASEMENT LINE (T)
—	SURVEY LINE
P	PROPERTY LINE (P/L)
L	
SR	SLOPE RIGHTS
6f	6F PROPERTY BOUNDARY
4f	4F PROPERTY BOUNDARY
HAZ	HAZARDOUS WASTE

**EPSC LAYOUT PLAN SYMBOLGY**

**EPSC MEASURES**

—	FILTER CURTAIN
—	SILT FENCE
—	SILT FENCE WOVEN WIRE
—	CHECK DAM
—	DISTURBED AREAS REQUIRING RE-VEGETATION
—	EROSION MATTING

SEE EPSC DETAIL SHEETS FOR ADDITIONAL SYMBOLGY

**ENVIRONMENTAL RESOURCES**

—	WETLAND BOUNDARY
—	RIPARIAN BUFFER ZONE
—	WETLAND BUFFER ZONE
—	SOIL TYPE BOUNDARY
— T&E —	THREATENED & ENDANGERED SPECIES
HAZ	HAZARDOUS WASTE AREA
AG	AGRICULTURAL LAND
HABITAT	FISH & WILDLIFE HABITAT
FLOOD PLAIN	FLOOD PLAIN
OHW	ORDINARY HIGH WATER (OHW)
—	STORM WATER
—	USDA FOREST SERVICE LANDS
—	WILDLIFE HABITAT SUIT/CONN

**ARCHEOLOGICAL & HISTORIC**

— ARCH —	ARCHEOLOGICAL BOUNDARY
— HISTORIC DIST —	HISTORIC DISTRICT BOUNDARY
— HISTORIC —	HISTORIC AREA
(H)	HISTORIC STRUCTURE

**CONVENTIONAL TOPOGRAPHIC SYMBOLGY**

**EXISTING FEATURES**

—	ROAD EDGE PAVEMENT
—	ROAD EDGE GRAVEL
—	DRIVEWAY EDGE
—	DITCH
—	FOUNDATION
—	FENCE (EXISTING)
—	FENCE WOOD POST
—	FENCE STEEL POST
—	GARDEN
—	ROAD GUARDRAIL
—	RAILROAD TRACKS
—	CULVERT (EXISTING)
—	STONE WALL
—	WALL
—	WOOD LINE
—	BRUSH LINE
—	HEDGE
—	BODY OF WATER EDGE
—	LEDGE EXPOSED

PROJECT NAME: ESSEX  
PROJECT NUMBER: BF 5400(9)

FILE NAME: s13d654leg.dgn PLOT DATE: 07-AUG-2017  
PROJECT LEADER: R. YOUNG DRAWN BY: T. MATTHEWS  
DESIGNED BY: ----- CHECKED BY: -----  
LEGEND SHEET SHEET 3 OF 27

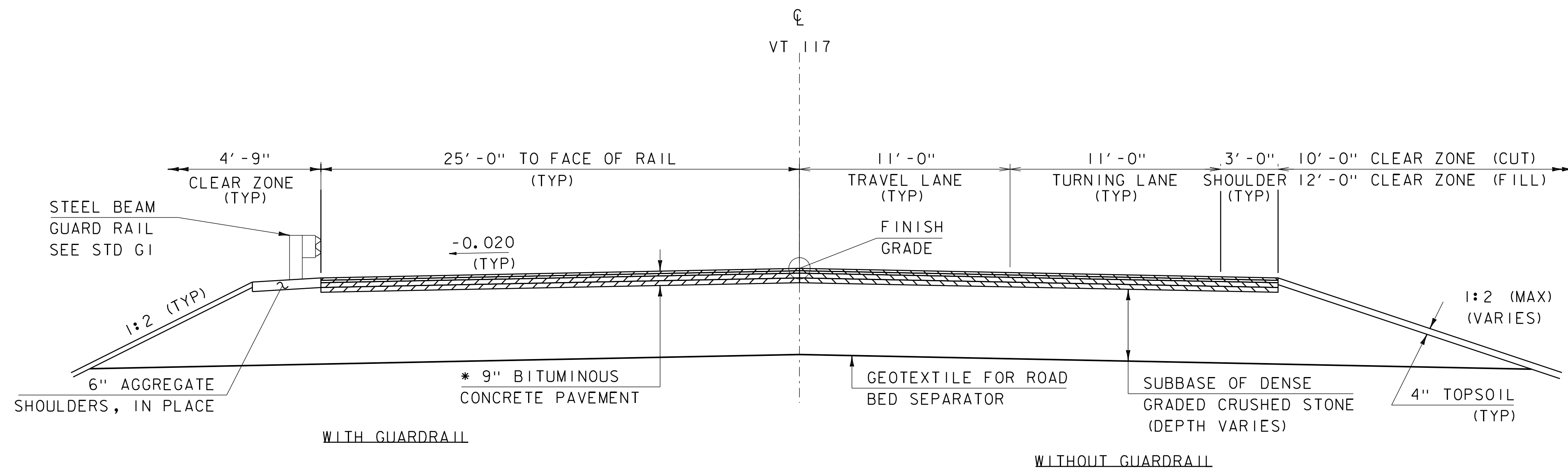

**ROADWAY TYPICAL SECTION**

- \* 1 1/2" SUPERPAVE BITUMINOUS CONCRETE PAVEMENT, TYPE IVS
- 1 1/2" SUPERPAVE BITUMINOUS CONCRETE PAVEMENT, TYPE IVS
- 3" SUPERPAVE BITUMINOUS CONCRETE PAVEMENT, TYPE IIIS
- 3" SUPERPAVE BITUMINOUS CONCRETE PAVEMENT, TYPE IIIS

MATERIAL TOLERANCES (IF USED ON PROJECT)	
SURFACE	
- PAVEMENT (TOTAL THICKNESS)	+/- 1/4"
- AGGREGATE SURFACE COURSE	+/- 1/2"
SUBBASE	+/- 1"
SAND BORROW	+/- 1"

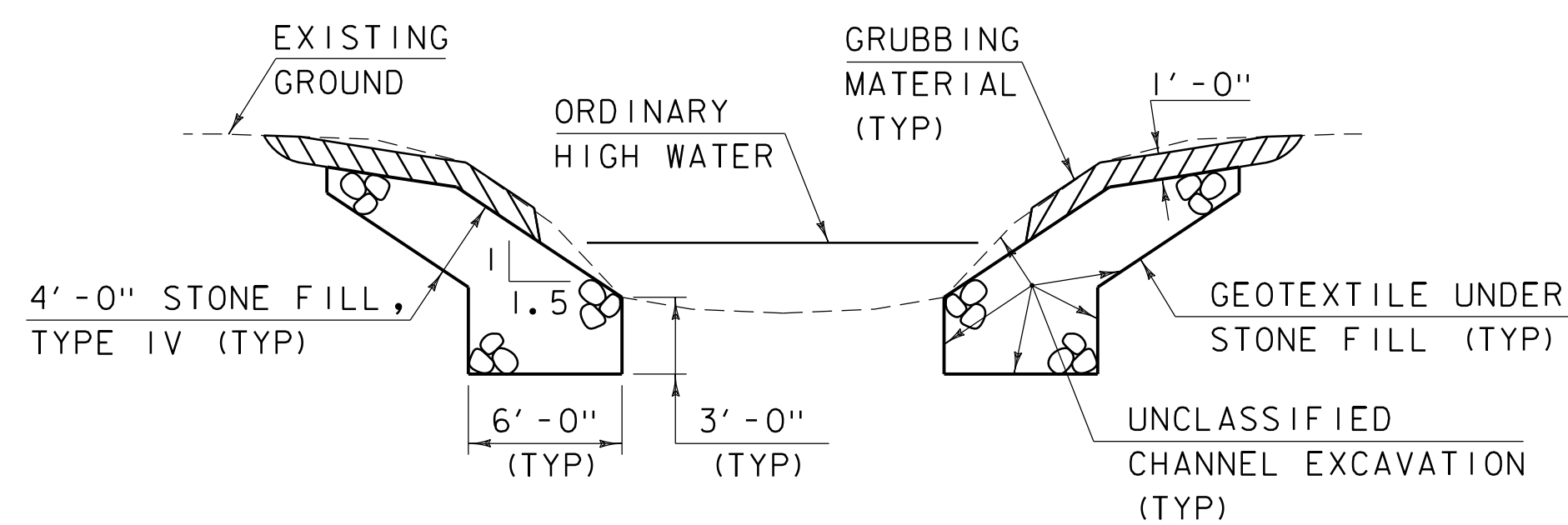

**TYPICAL CHANNEL SECTION  
(NOT TO SCALE)**

**NOTES:**

1. WHENEVER CHANNEL SLOPE INTERSECTS ROADWAY SUBBASE, GRUBBING MATERIAL SHALL BEGIN AT BOTTOM OF SUBBASE.
2. NO GRUBBING MATERIAL SHALL BE PLACED UNDER DOWNSPOUTS.

PROJECT NAME: ESSEX  
PROJECT NUMBER: BF 5400(9)

FILE NAME: sl3d654+yp.dgn  
PROJECT LEADER: R. YOUNG  
DESIGNED BY: G. DARGAN  
TYPICAL SECTIONS

PLOT DATE: 07-AUG-2017  
DRAWN BY: G. DARGAN  
CHECKED BY:  
SHEET 4 OF 27



STATE OF VERMONT

STEINER, PAUL M.

TOWN OF ESSEX

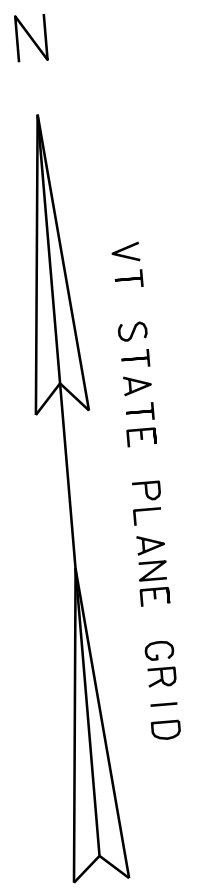

BEGIN PROJECT  
STA 124+50.00

BEGIN APPROACH  
STA 124+00.00

BEGIN BRIDGE  
STA 126+56.00  
FG = 290.76

END BRIDGE  
STA 126+98.53  
FG = 290.50

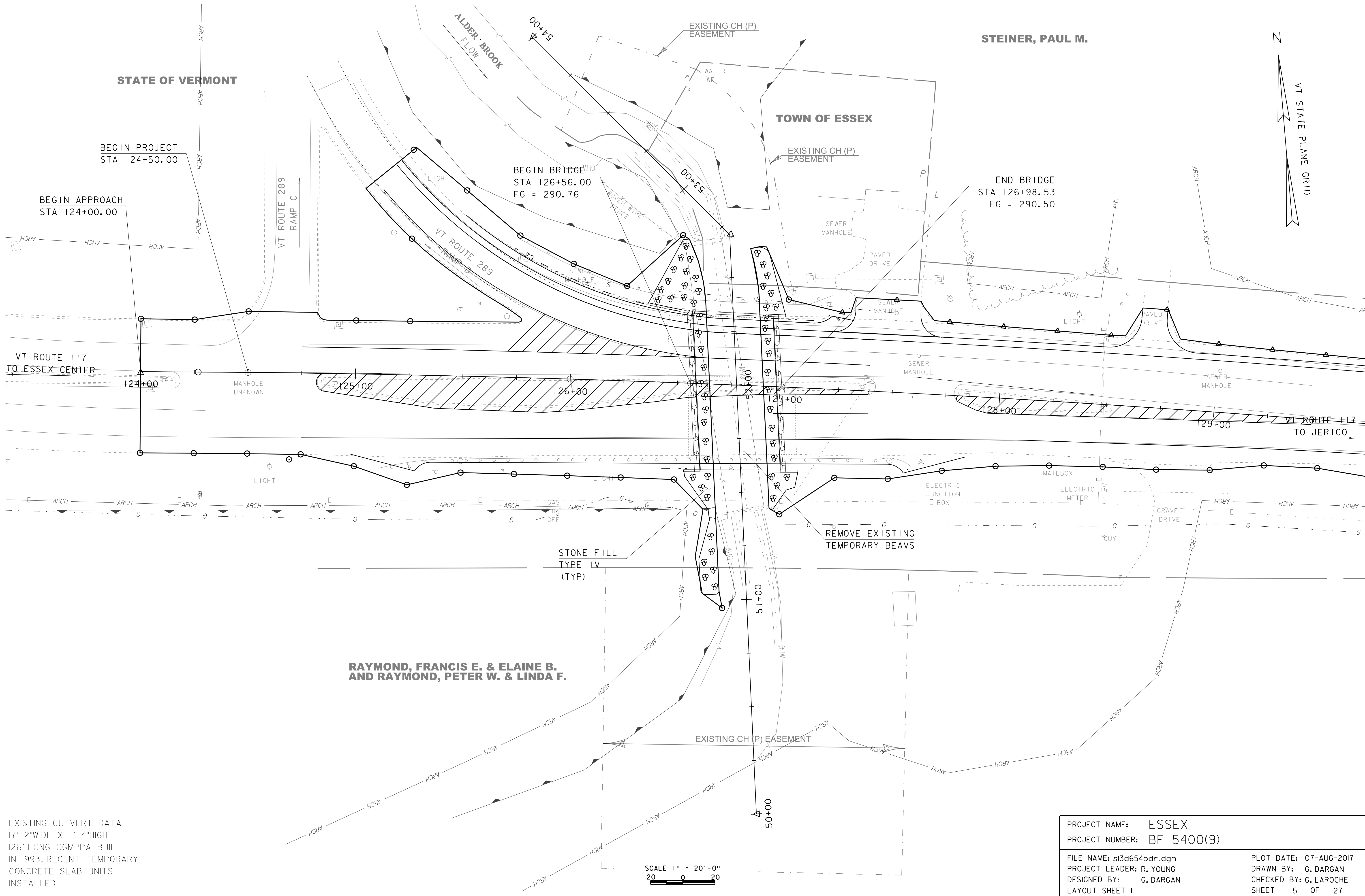

EXISTING CULVERT DATA  
17'-2" WIDE X 11'-4" HIGH  
126' LONG CGMPPA BUILT  
IN 1993. RECENT TEMPORARY  
CONCRETE SLAB UNITS  
INSTALLED

SCALE 1" = 20'-0"  
20 0 20

PROJECT NAME: ESSEX		PLOT DATE: 07-AUG-2017	
PROJECT NUMBER: BF 5400(9)		DRAWN BY: G. DARGAN	
FILE NAME: s13d654bdr.dgn	PROJECT LEADER: R. YOUNG	DESIGNED BY: G. DARGAN	CHECKED BY: G. LAROCHE
LAYOUT SHEET 1		SHEET 5 OF 27	

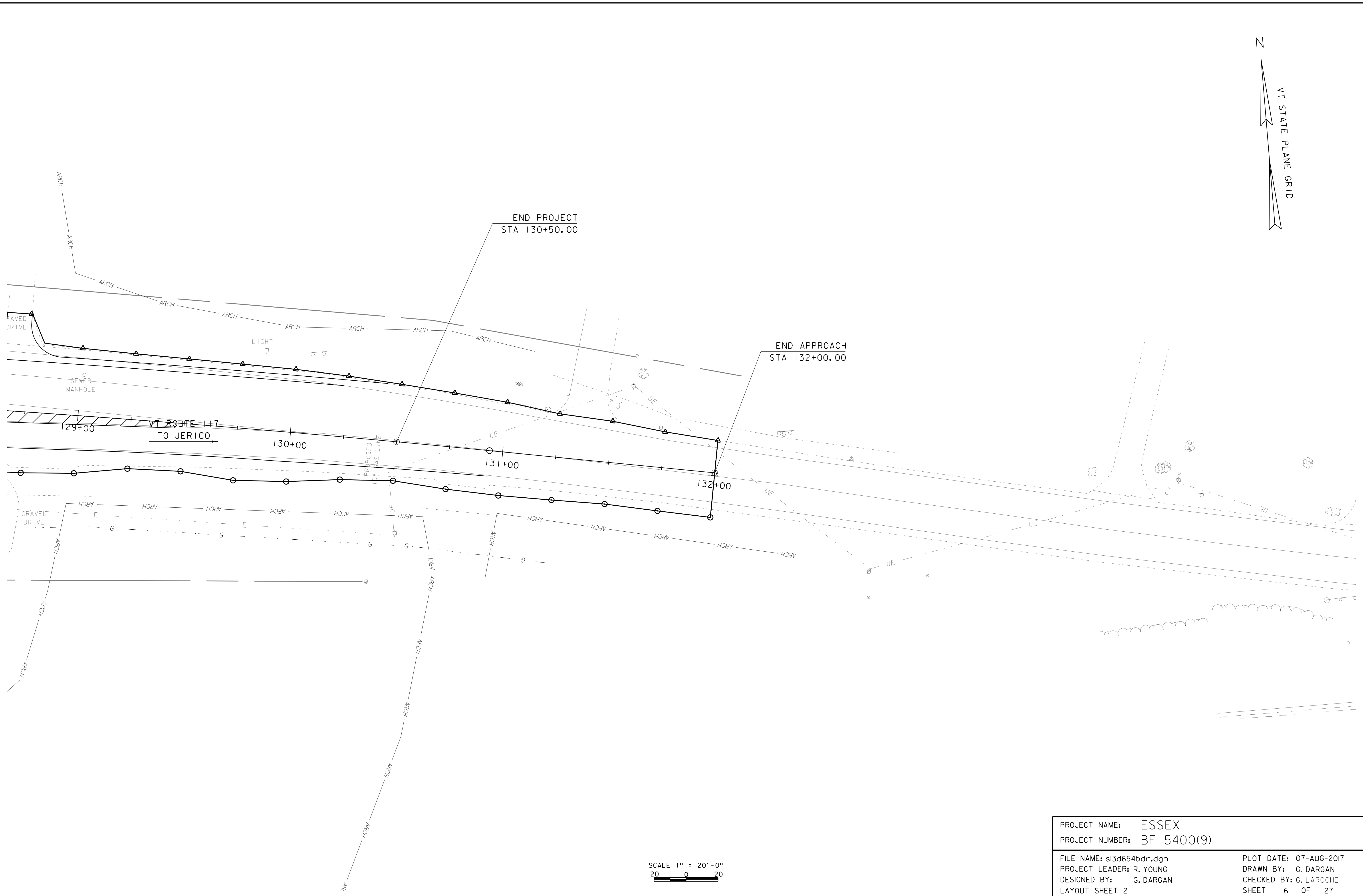
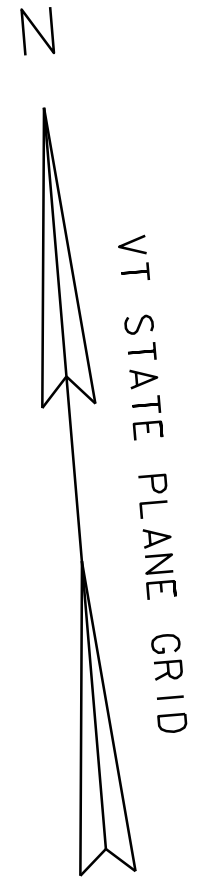

SCALE 1" = 20'-0"  
20 0 20

PROJECT NAME: ESSEX  
PROJECT NUMBER: BF 5400(9)

FILE NAME: s13d654bdr.dgn  
PROJECT LEADER: R. YOUNG  
DESIGNED BY: G. DARGAN  
LAYOUT SHEET 2

PLOT DATE: 07-AUG-2017  
DRAWN BY: G. DARGAN  
CHECKED BY: G. LAROCHE  
SHEET 6 OF 27

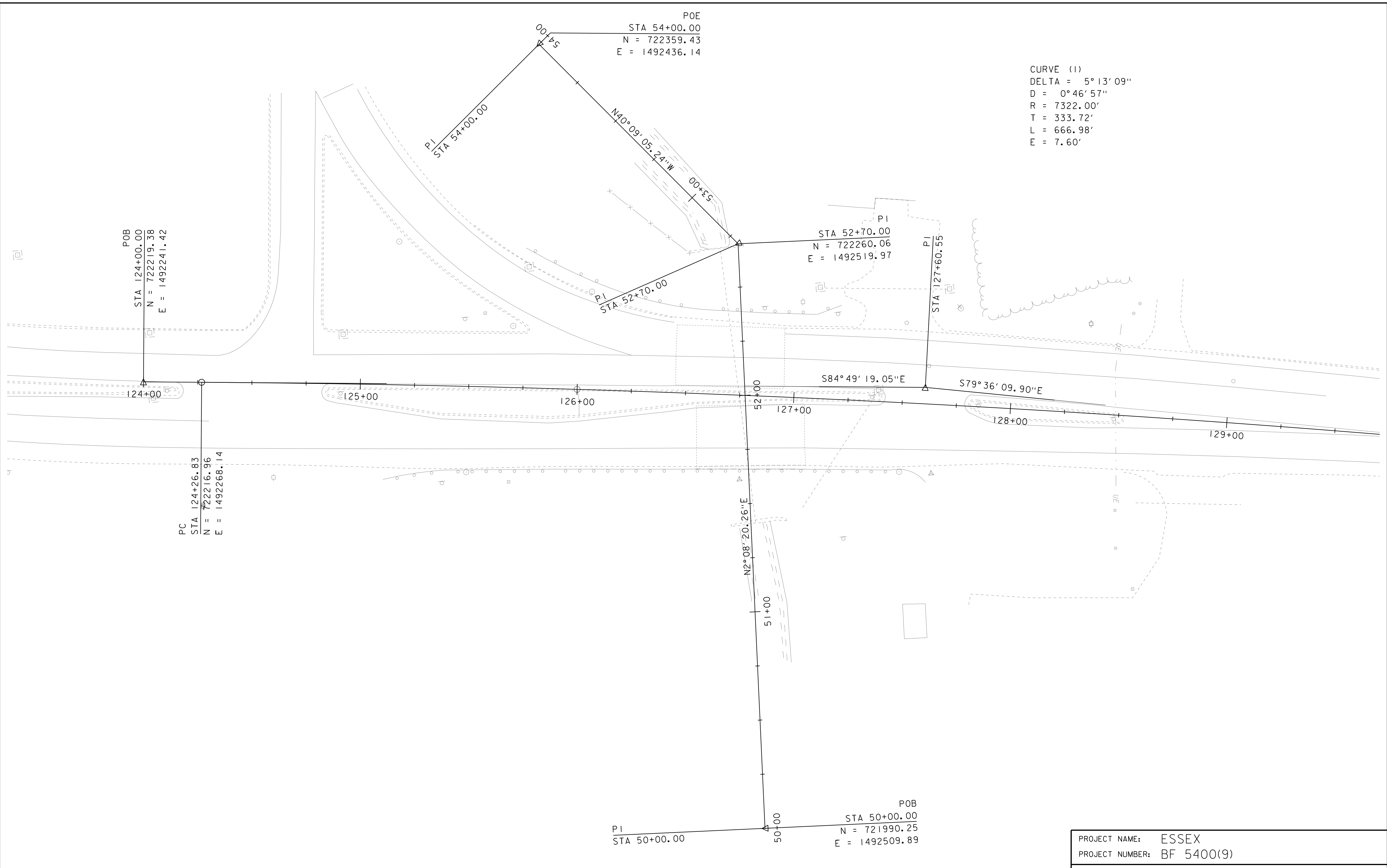

SCALE 1" = 20'-0"

PROJECT NAME: ESSEX	
PROJECT NUMBER: BF 5400(9)	
FILE NAME: s13d654bdr_ALG.dgn	PLOT DATE: 07-AUG-2017
PROJECT LEADER: R. YOUNG	DRAWN BY: G. DARGAN
DESIGNED BY: G. DARGAN	CHECKED BY: -----
ALIGNMENT SHEET 1	SHEET 7 OF 27

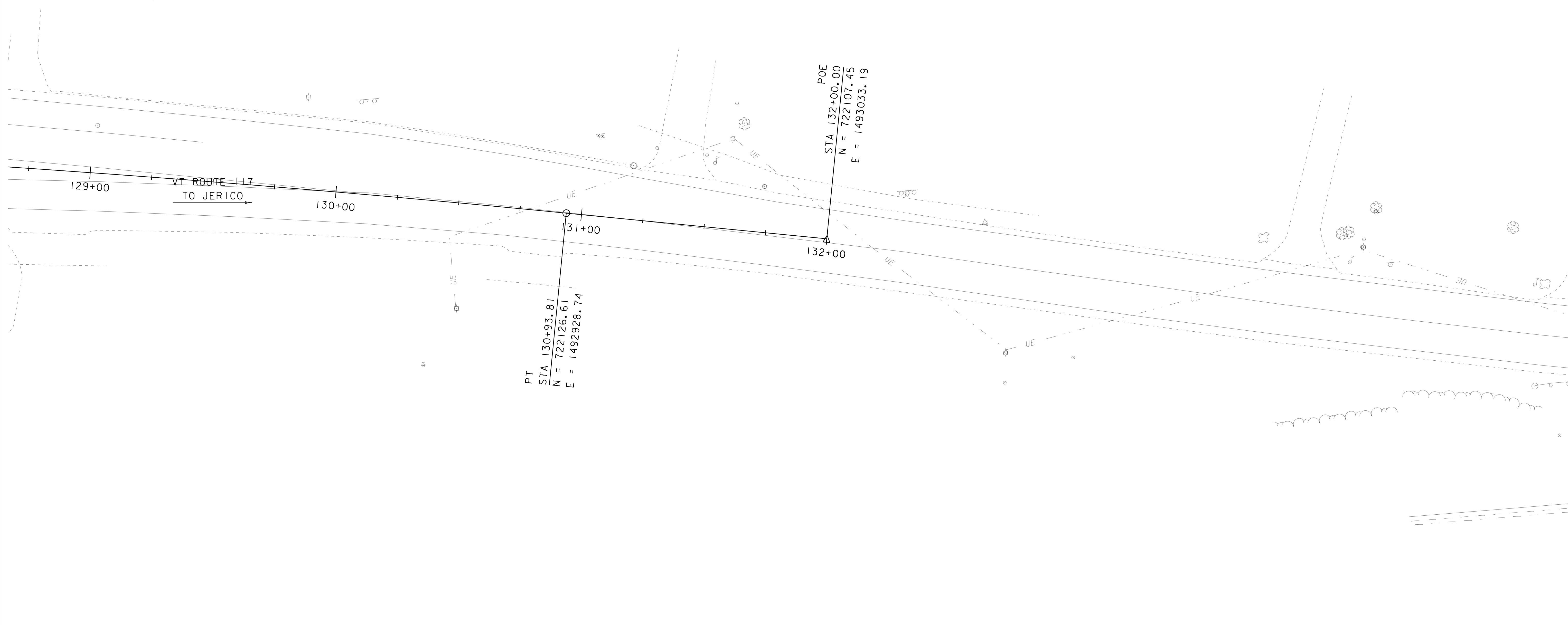
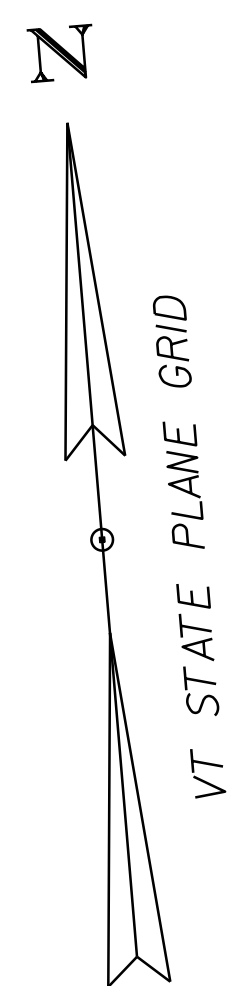
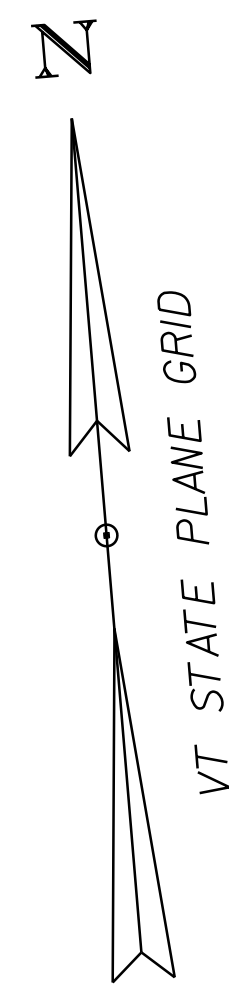

SCALE 1" = 20'-0"  
20 0 20

PROJECT NAME: ESSEX	PLOT DATE: 07-AUG-2017
PROJECT NUMBER: BF 5400(9)	DRAWN BY: G. DARGAN
FILE NAME: s13d654bdr_ALG.dgn	CHECKED BY: -----
PROJECT LEADER: R. YOUNG	SHEET 8 OF 27
DESIGNED BY: G. DARGAN	
ALIGNMENT SHEET 2	



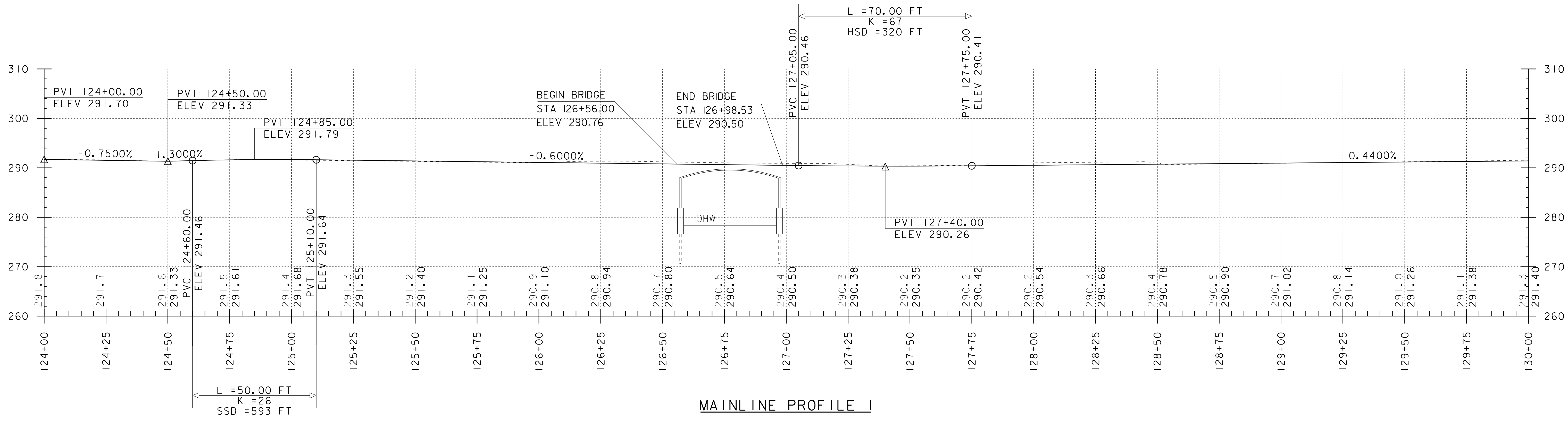

MAINLINE PROFILE 1

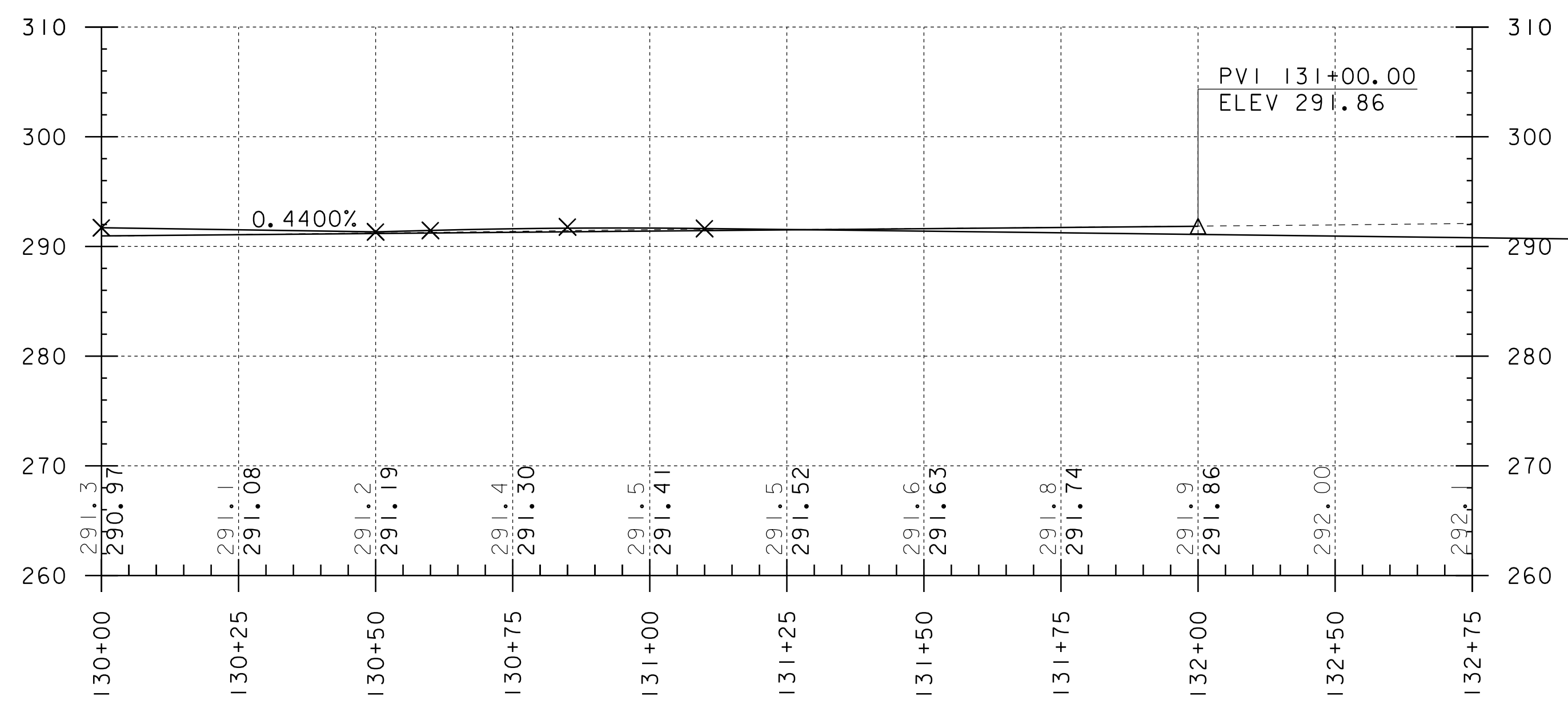

MAINLINE PROFILE 2

THE GRADES SHOWN TO THE TENTH ARE THE EXISTING GROUND ELEVATIONS ALONG THE PROPOSED ALIGNMENT.

THE GRADES SHOWN TO THE NEAREST HUNDREDTH ARE THE FINISH GRADES ALONG THE PROPOSED ALIGNMENT.

PROJECT NAME: ESSEX	
PROJECT NUMBER: BF 5400(9)	
FILE NAME: s13d654pro.dgn	PLOT DATE: 07-AUG-2017
PROJECT LEADER: R. YOUNG	DRAWN BY: T. MATTHEWS
DESIGNED BY: T. MATTHEWS	CHECKED BY: -----
MAINLINE PROFILE	SHEET 9 OF 27

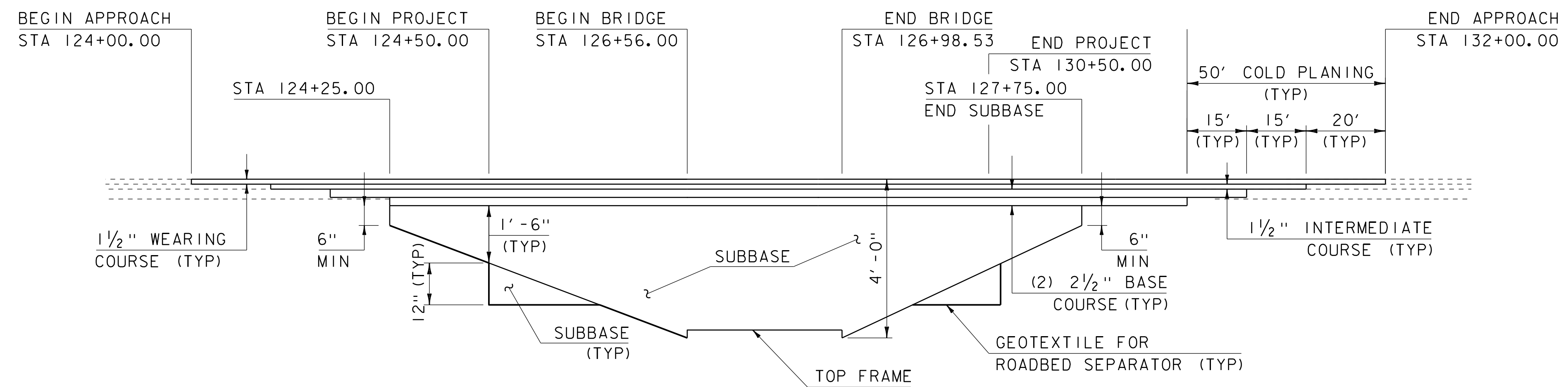

**MATERIAL TRANSITION**

HOR. SCALE 1" = 20'-0"  
 VER. SCALE 1" = 2'-0"

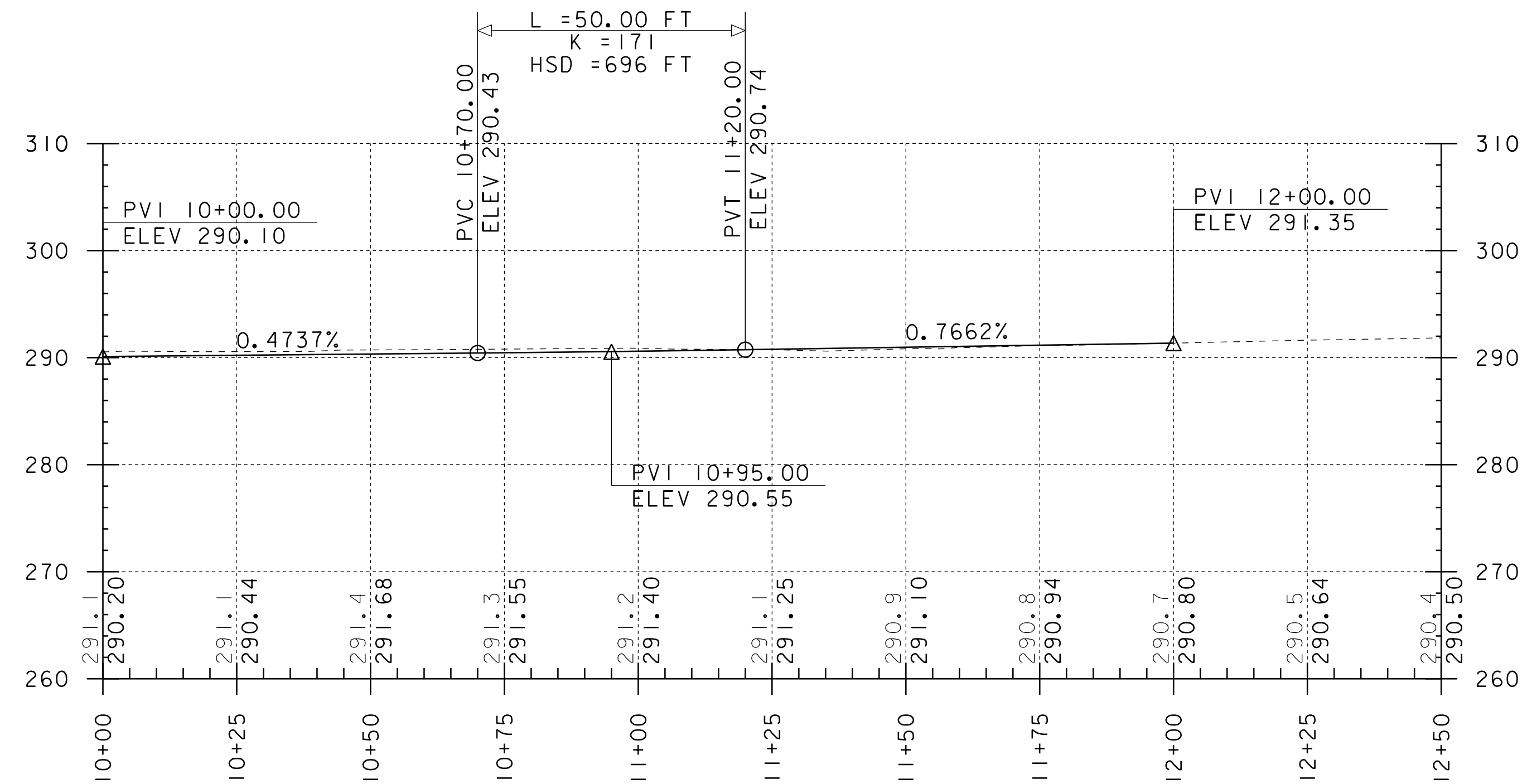

**ONRAMP PROFILE**

PROJECT NAME: ESSEX  
 PROJECT NUMBER: BF 5400(9)

FILE NAME: s13d654pro.dgn  
 PROJECT LEADER: R. YOUNG  
 DESIGNED BY: G. DARGAN  
 RAMP PROFILE AND MATERIAL TRANSITION

PLOT DATE: 07-AUG-2017  
 DRAWN BY: G. DARGAN  
 CHECKED BY:  
 SHEET 10 OF 27

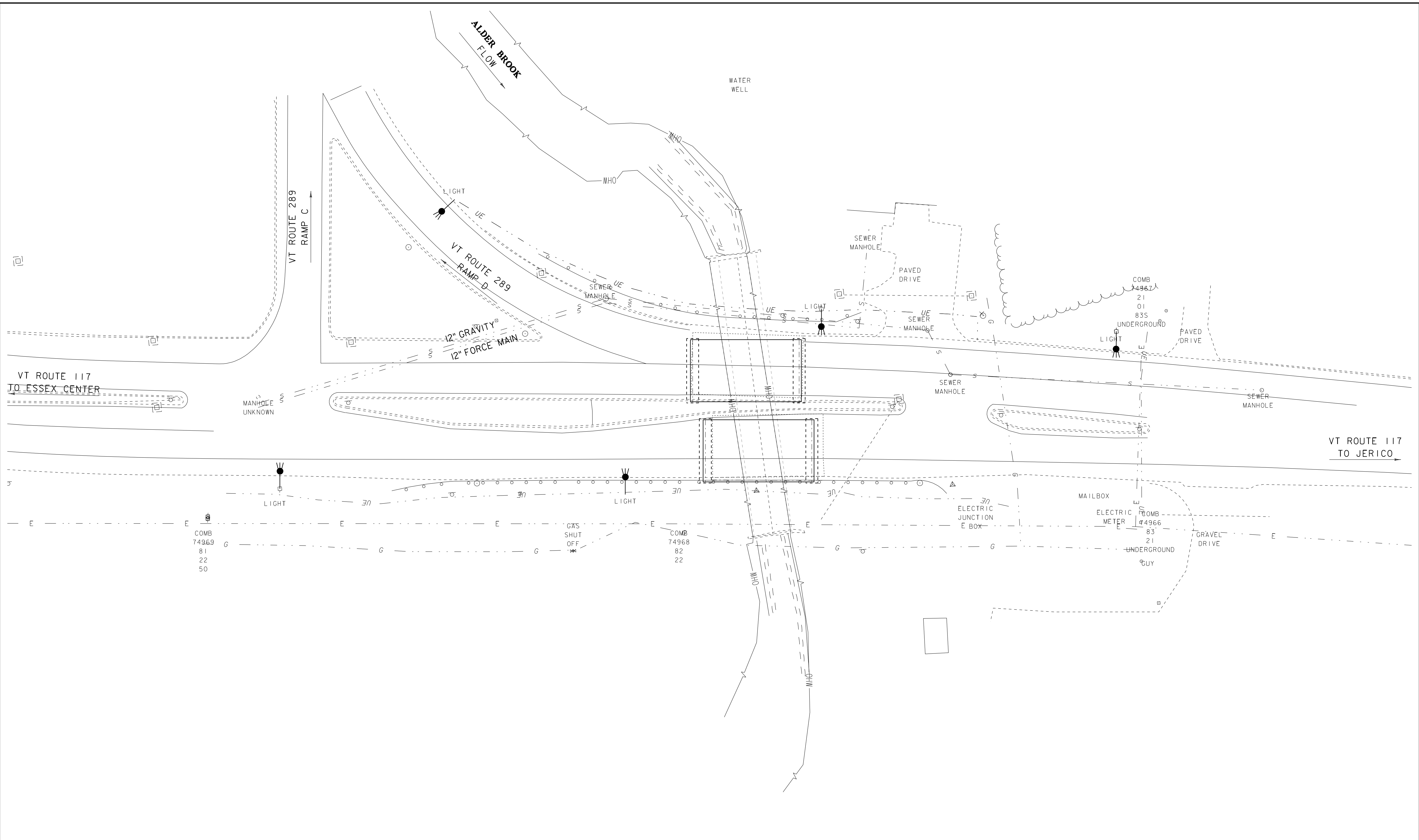

EXISTING CULVERT DATA  
 17'-2" WIDE X 11'-4" HIGH  
 126' LONG CGMPPA BUILT  
 IN 1993. RECENT TEMPORARY  
 CONCRETE SLAB UNITS  
 INSTALLED

SCALE 1" = 20'-0"  
 20 0 20

PROJECT NAME: ESSEX	
PROJECT NUMBER: BF 5400(9)	
FILE NAME: s13d654bdr.dgn	PLOT DATE: 07-AUG-2017
PROJECT LEADER: R. YOUNG	DRAWN BY: G. DARGAN
DESIGNED BY: G. DARGAN	CHECKED BY: G. LAROCHE
UTILITY SHEET 1	SHEET 11 OF 27

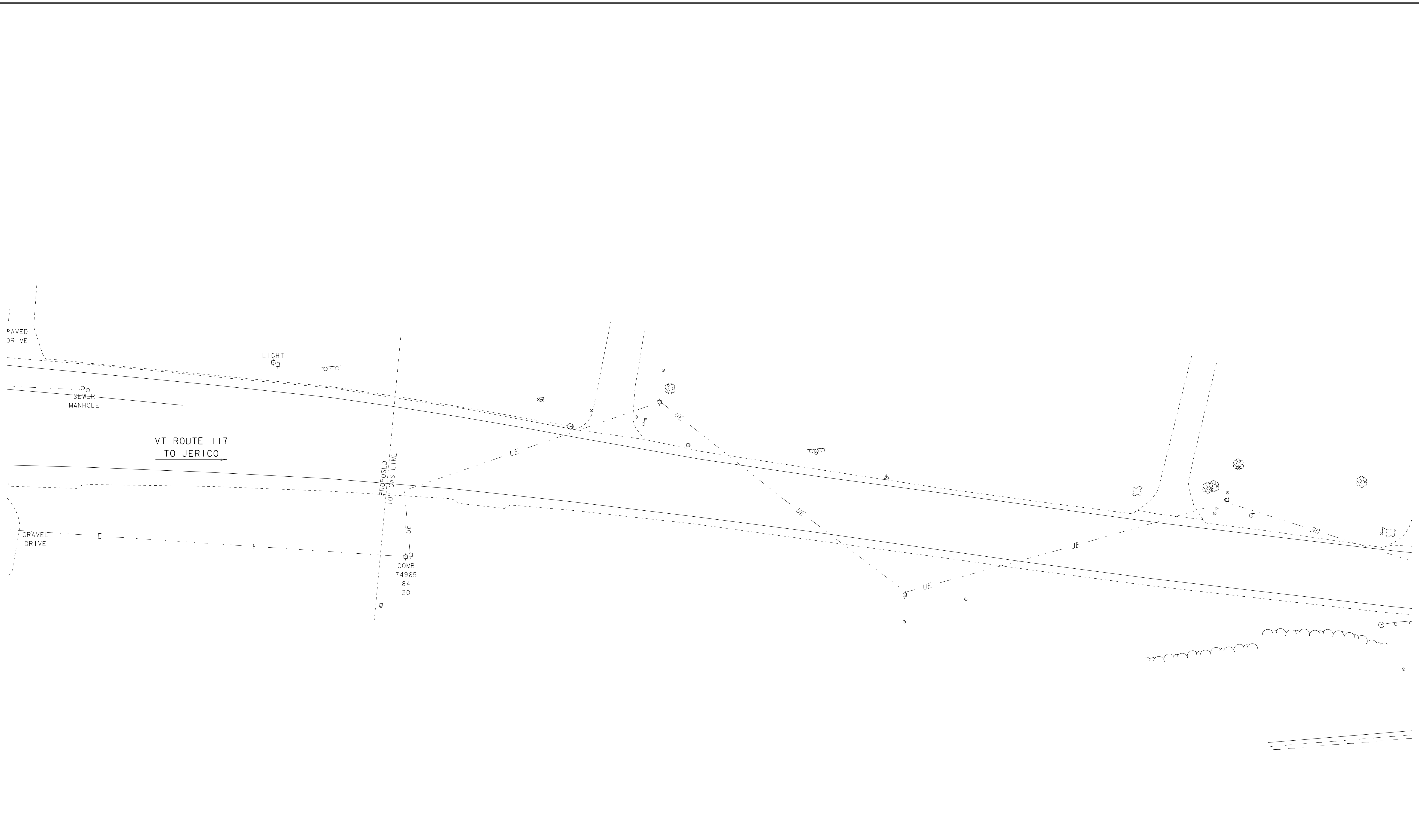

SCALE 1" = 20'-0"  
 20 0 20

PROJECT NAME:	ESSEX	PLOT DATE:	07-AUG-2017
PROJECT NUMBER:	BF 5400(9)	DRAWN BY:	G. DARGAN
FILE NAME:	sl3d654bdr.dgn	CHECKED BY:	G. LAROCHE
PROJECT LEADER:	R. YOUNG	UTILITY SHEET 2	SHEET 12 OF 27
DESIGNED BY:	G. DARGAN		

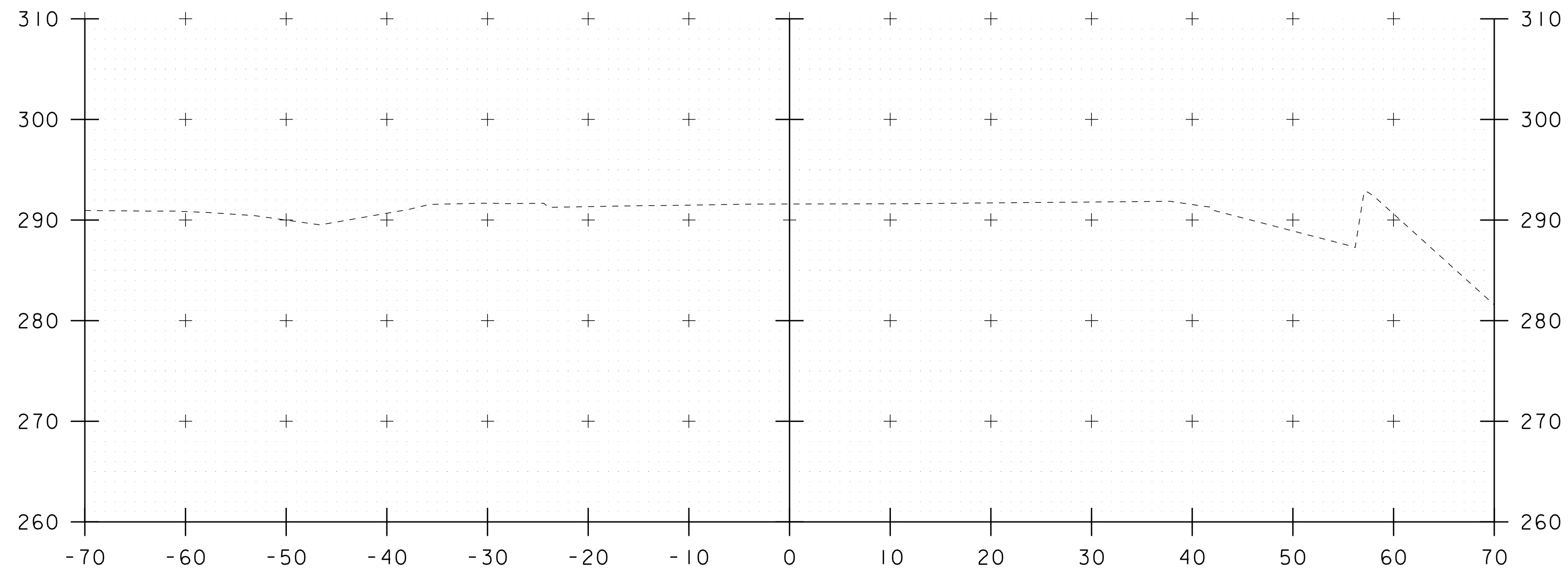

124+25

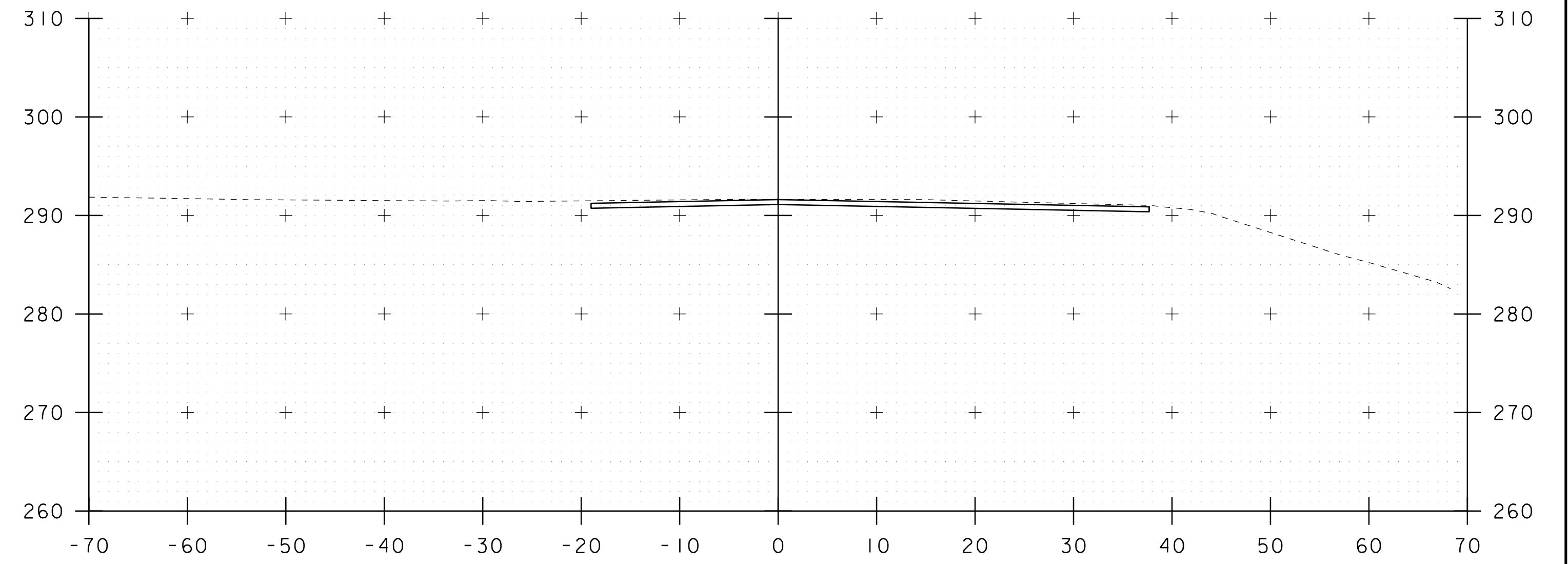

124+75

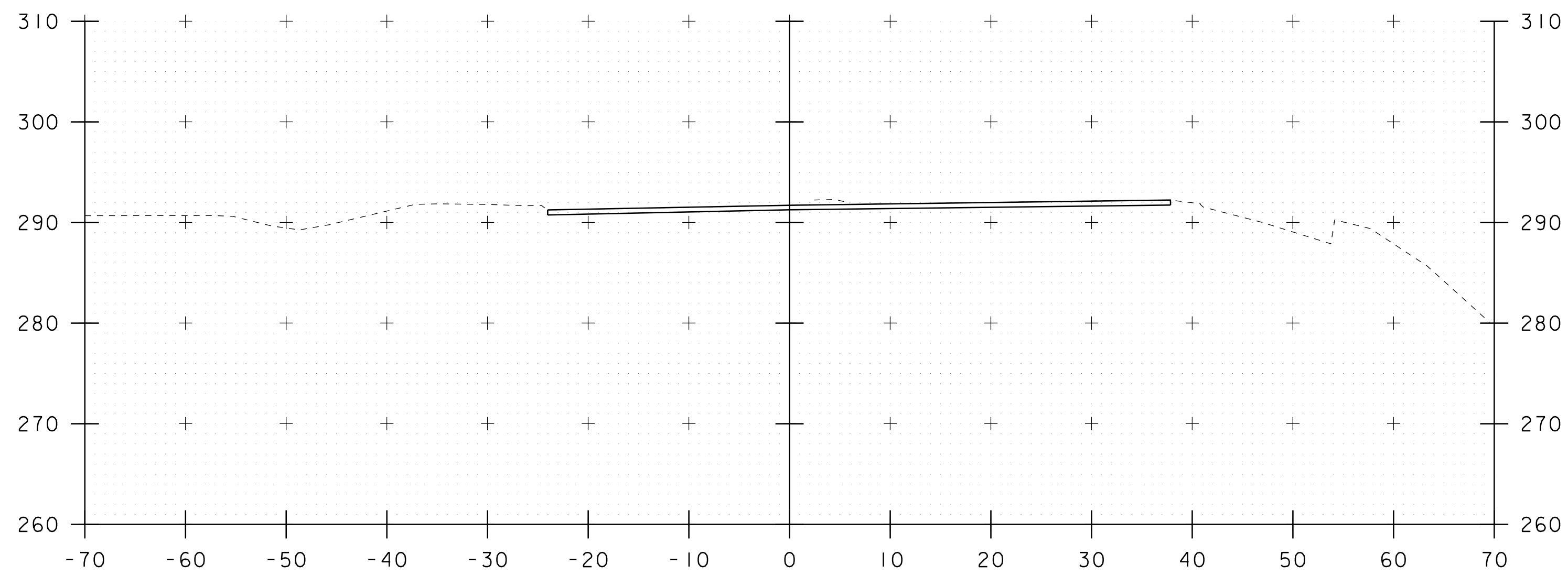

124+00

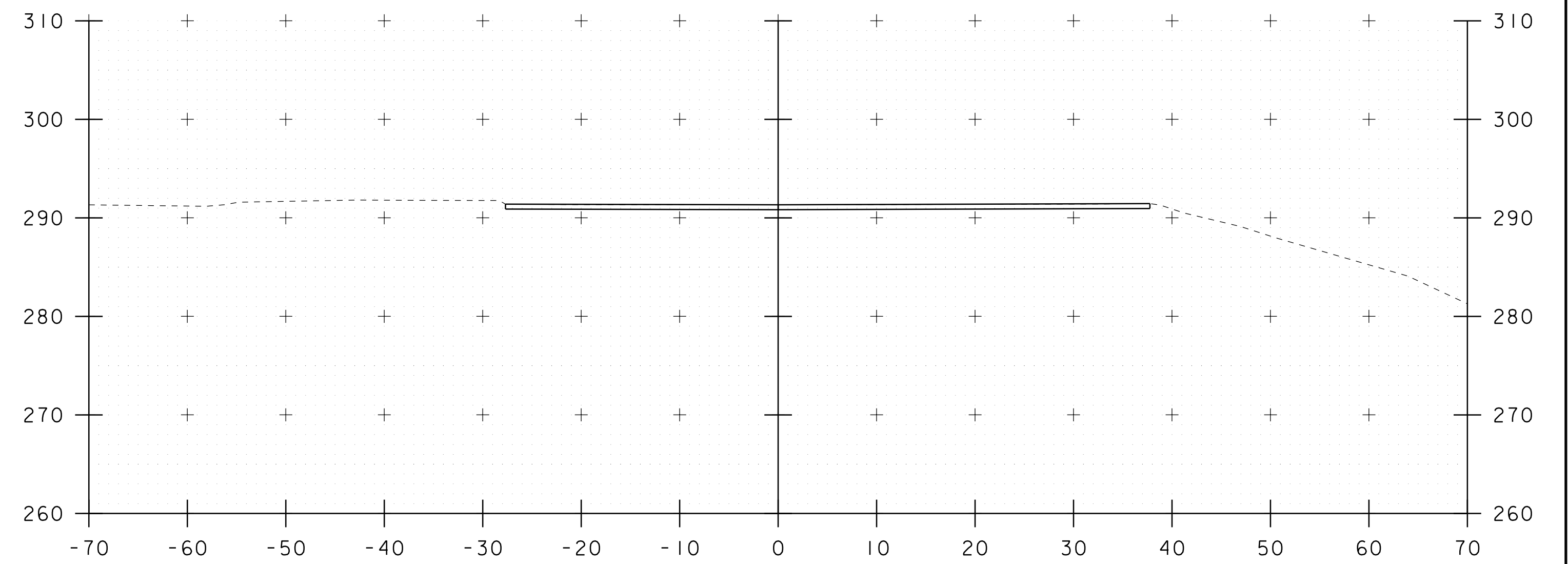

124+50

STA. 124+00 TO STA. 124+75

<b>PROJECT NAME:</b> ESSEX		<b>PLOT DATE:</b> 07-AUG-2017	
<b>PROJECT NUMBER:</b> BF 5400(9)		<b>DRAWN BY:</b> G. DARGAN	
<b>FILE NAME:</b> sl3d654xs.dgn		<b>DESIGNED BY:</b> G. DARGAN	
<b>PROJECT LEADER:</b> R. YOUNG		<b>CHECKED BY:</b> -----	
<b>MAINLINE CROSS SECTIONS 1</b>		<b>SHEET 13 OF 27</b>	



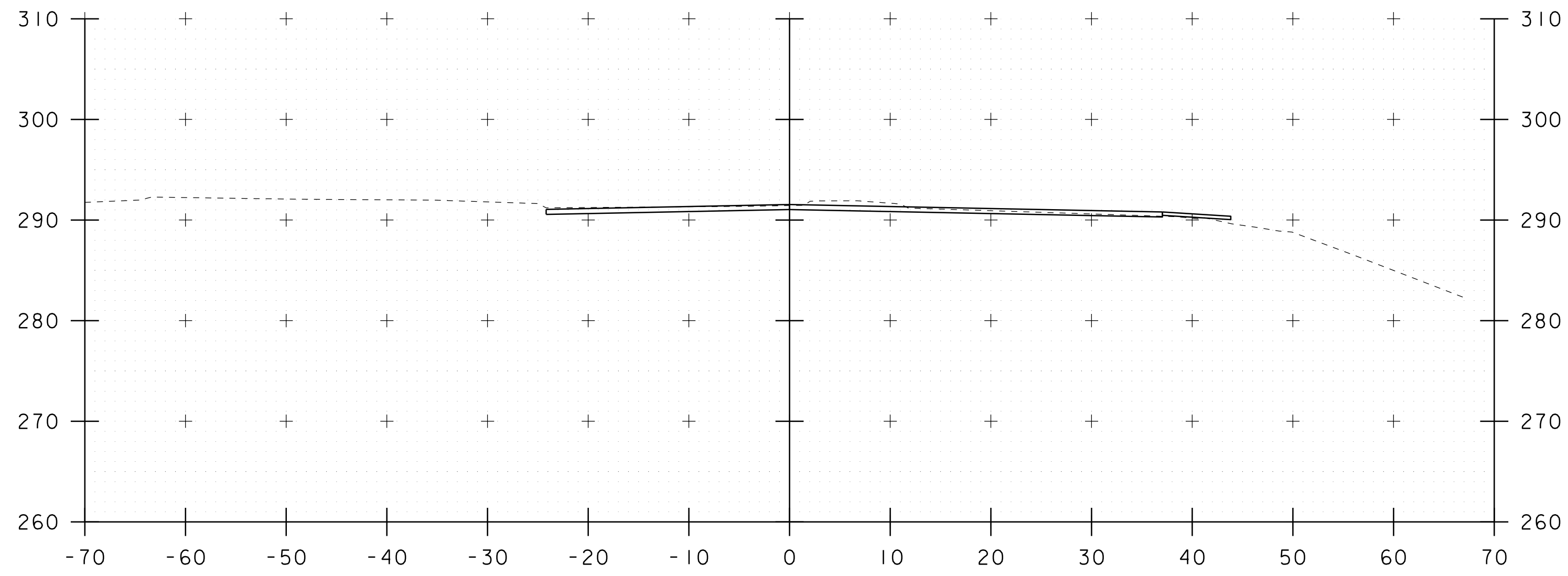

125+25

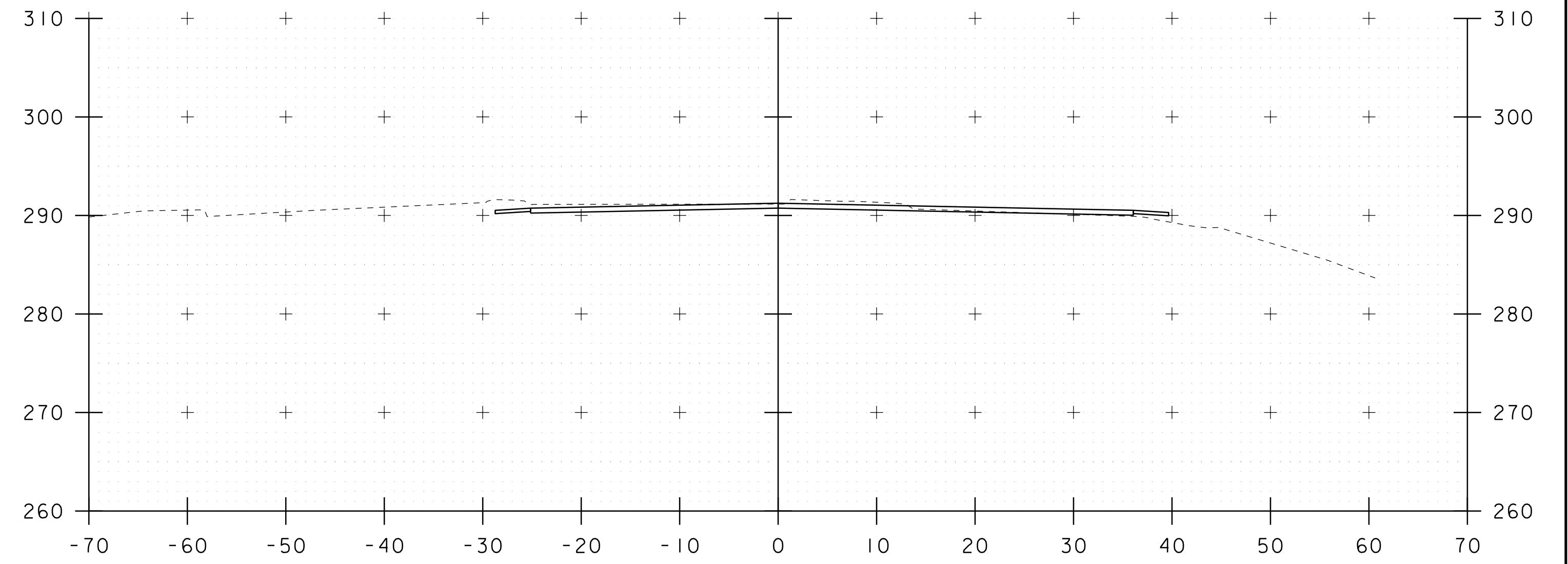

125+75

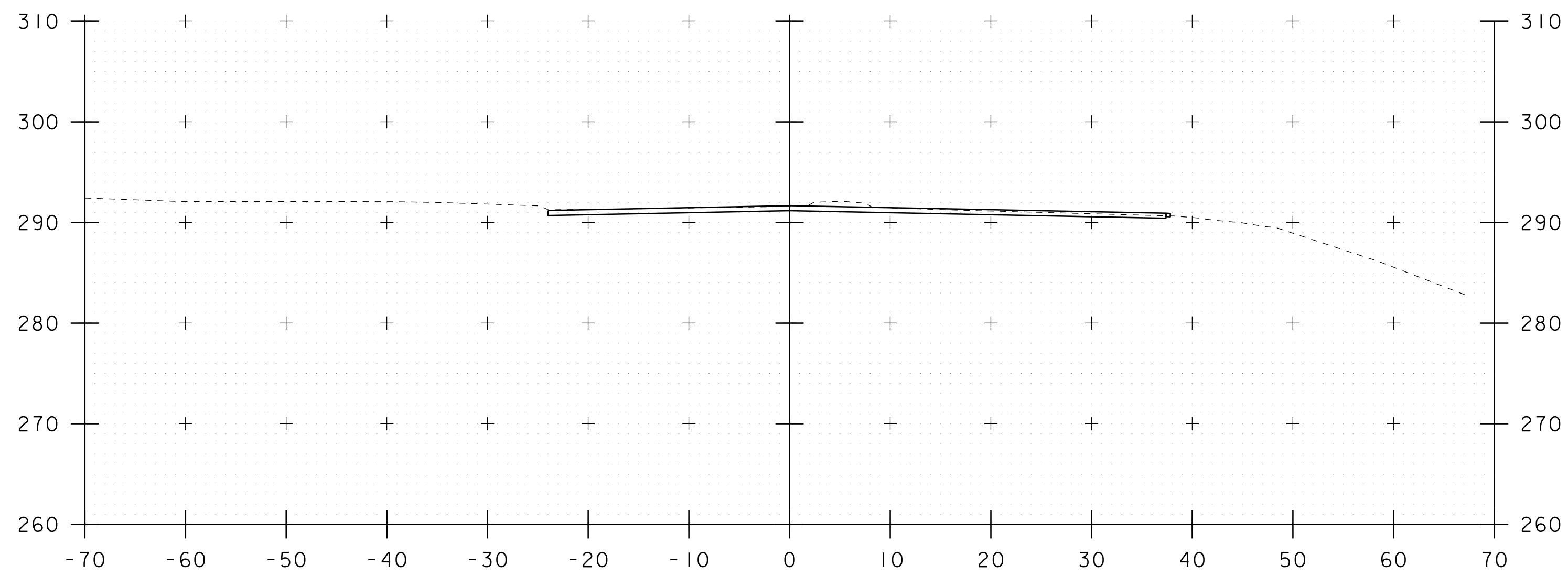

125+00

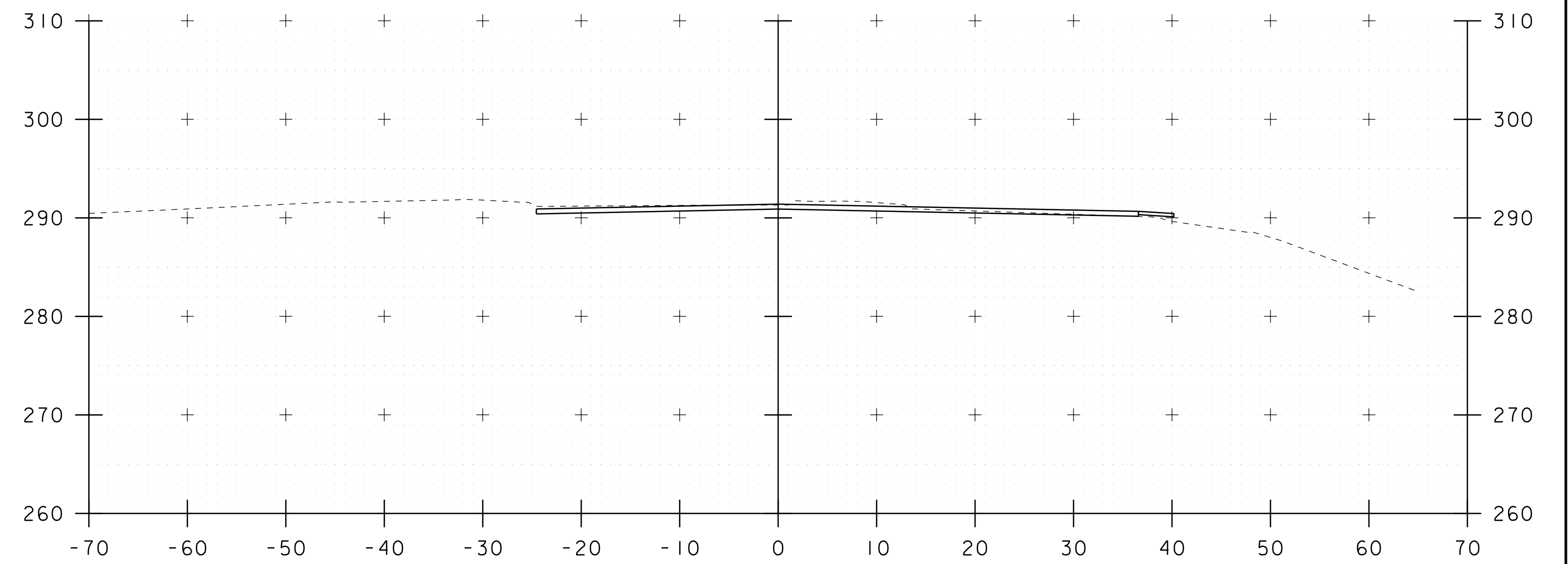

125+50

STA. 125+00 TO STA. 125+75

<b>PROJECT NAME:</b> ESSEX		<b>PLOT DATE:</b> 07-AUG-2017	
<b>PROJECT NUMBER:</b> BF 5400(9)		<b>DRAWN BY:</b> G. DARGAN	
<b>FILE NAME:</b> sl3d654xs.dgn		<b>DESIGNED BY:</b> G. DARGAN	
<b>PROJECT LEADER:</b> R. YOUNG		<b>CHECKED BY:</b> -----	
<b>MAINLINE CROSS SECTIONS 2</b>		<b>SHEET 14 OF 27</b>	

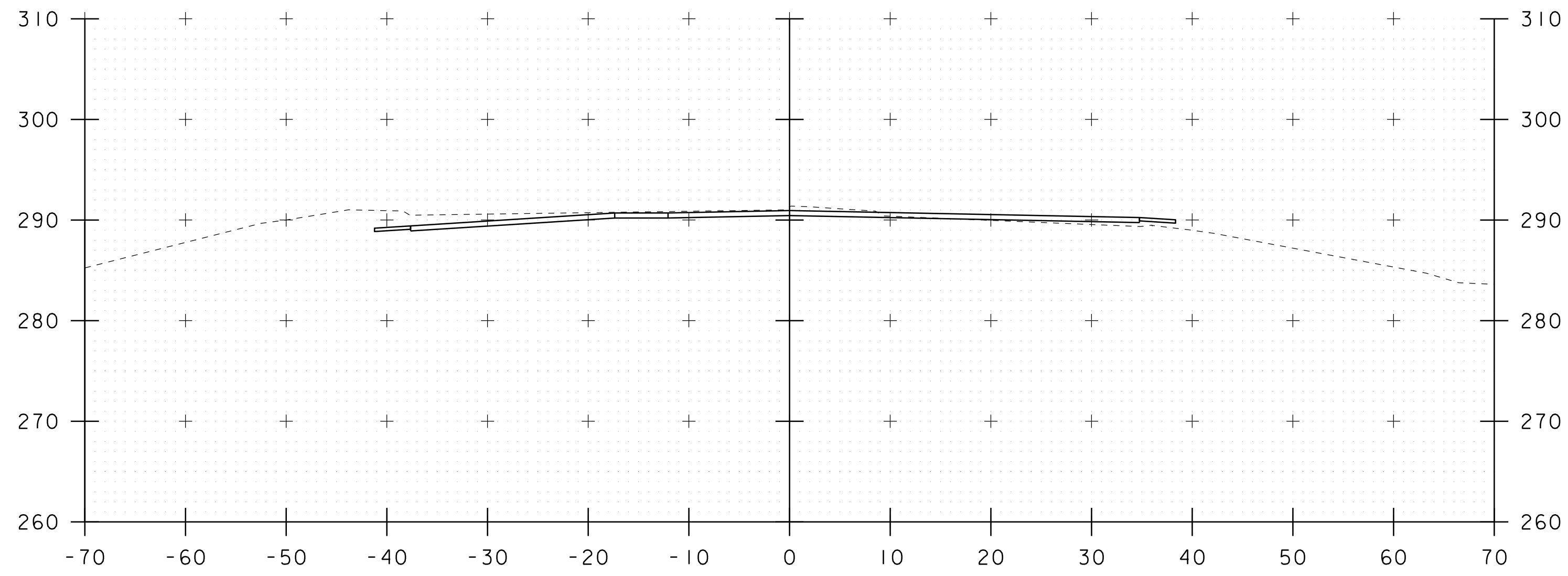

126+25

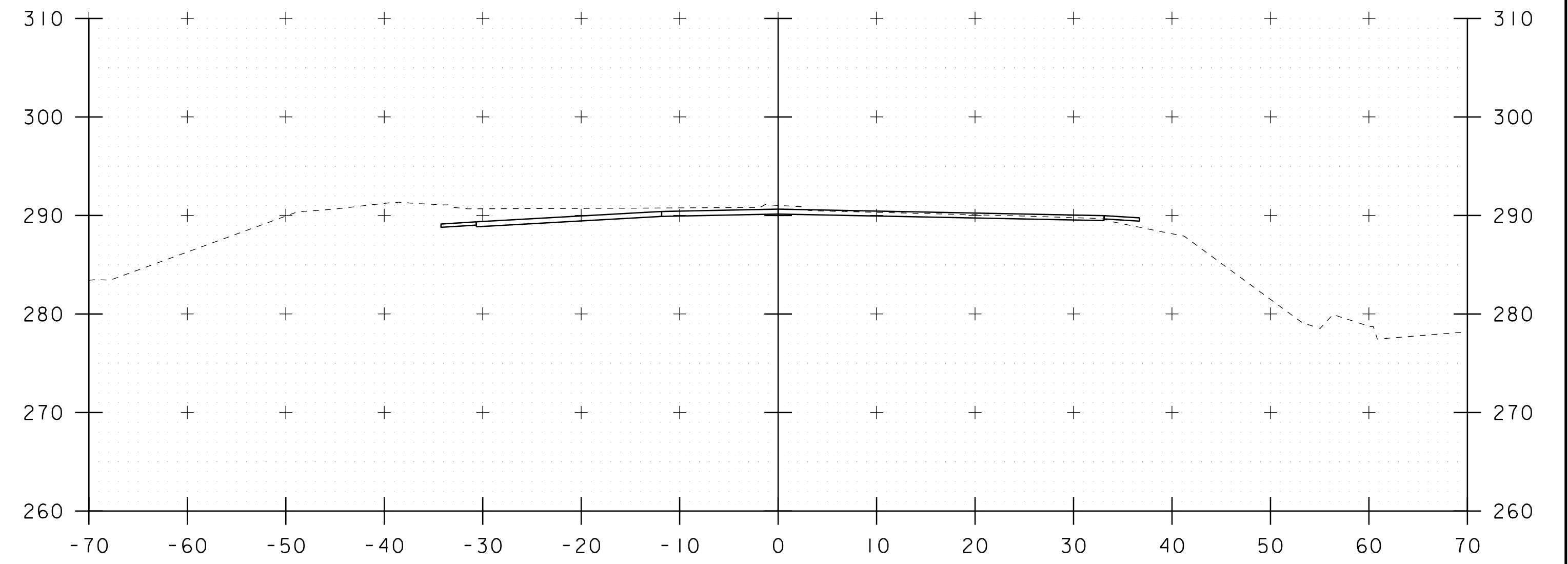

126+75

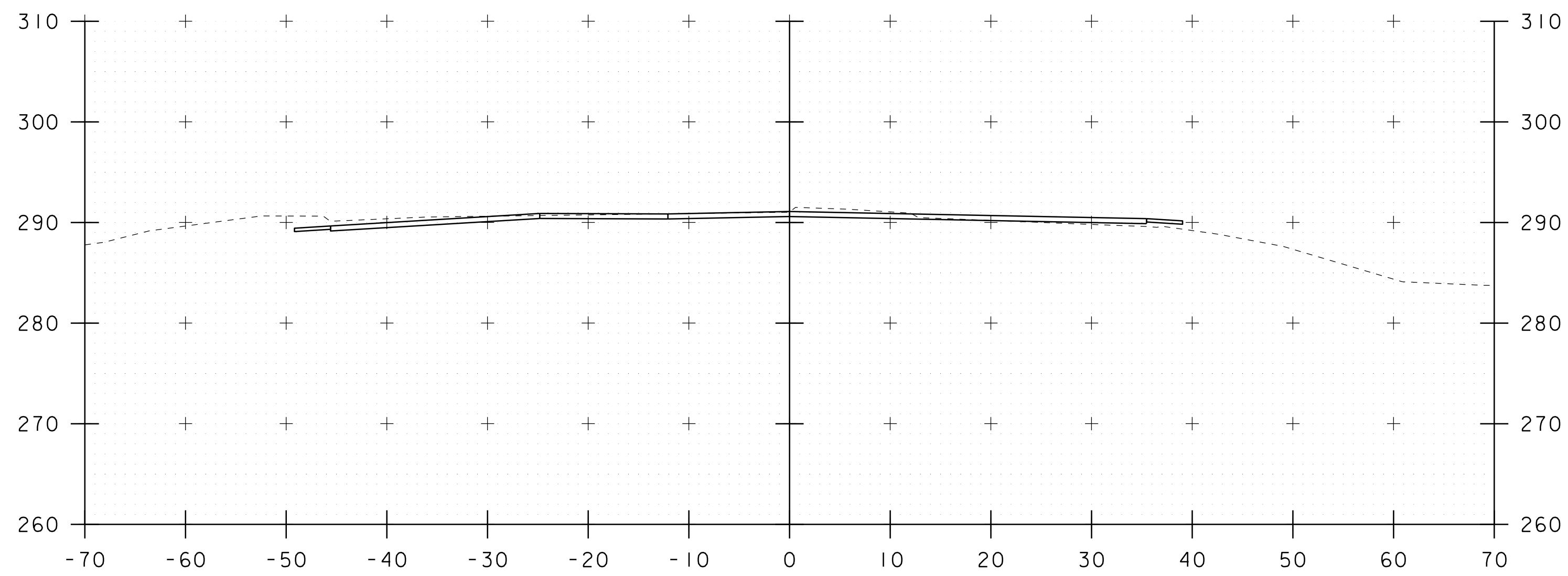

126+00

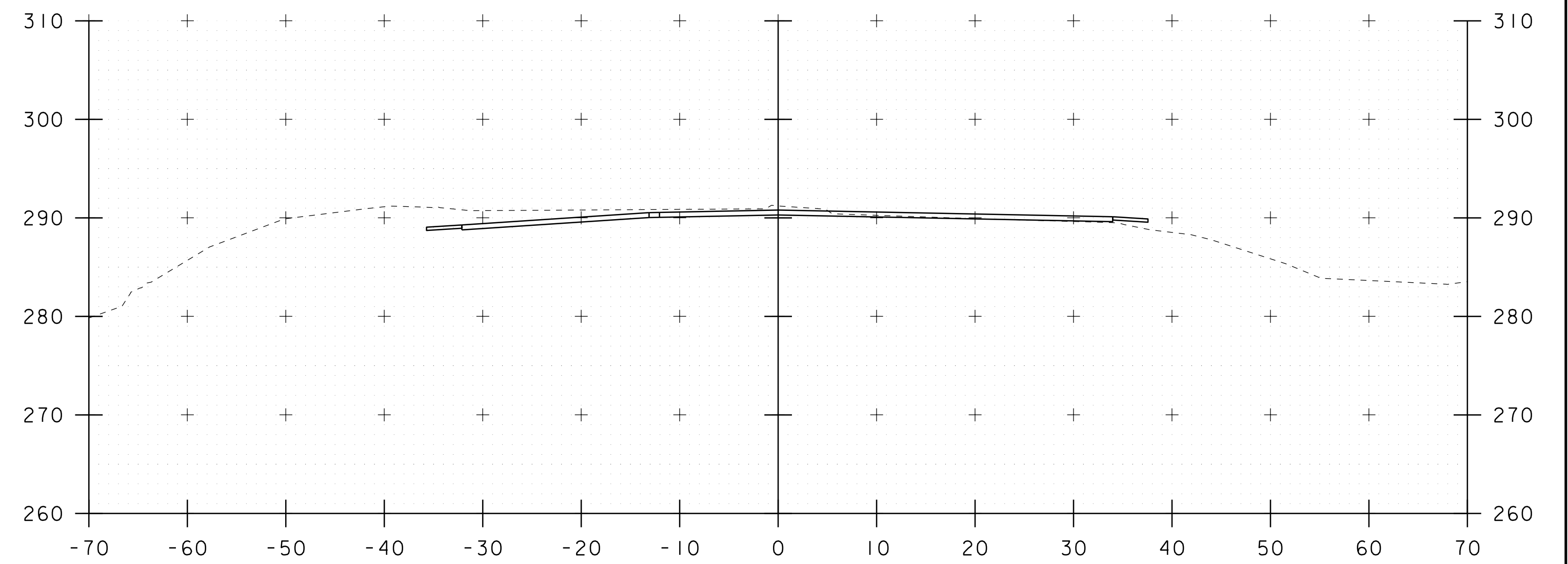

126+50

STA. 126+00 TO STA. 126+75

<b>PROJECT NAME:</b> ESSEX		<b>PLOT DATE:</b> 07-AUG-2017	
<b>PROJECT NUMBER:</b> BF 5400(9)		<b>DRAWN BY:</b> G. DARGAN	
<b>FILE NAME:</b> sl3d654xs.dgn	<b>PROJECT LEADER:</b> R. YOUNG	<b>DESIGNED BY:</b> G. DARGAN	<b>CHECKED BY:</b> -----
<b>MAINLINE CROSS SECTIONS 3</b>		<b>SHEET</b> 15	<b>OF</b> 27

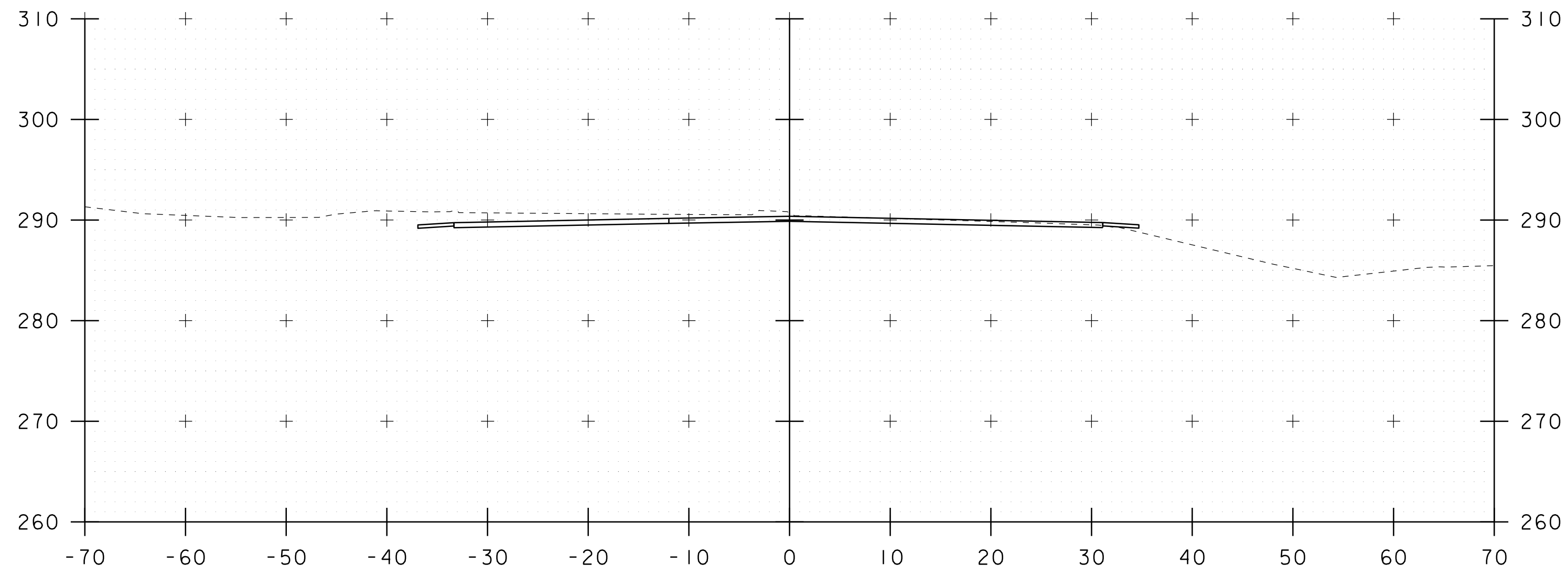

127+25

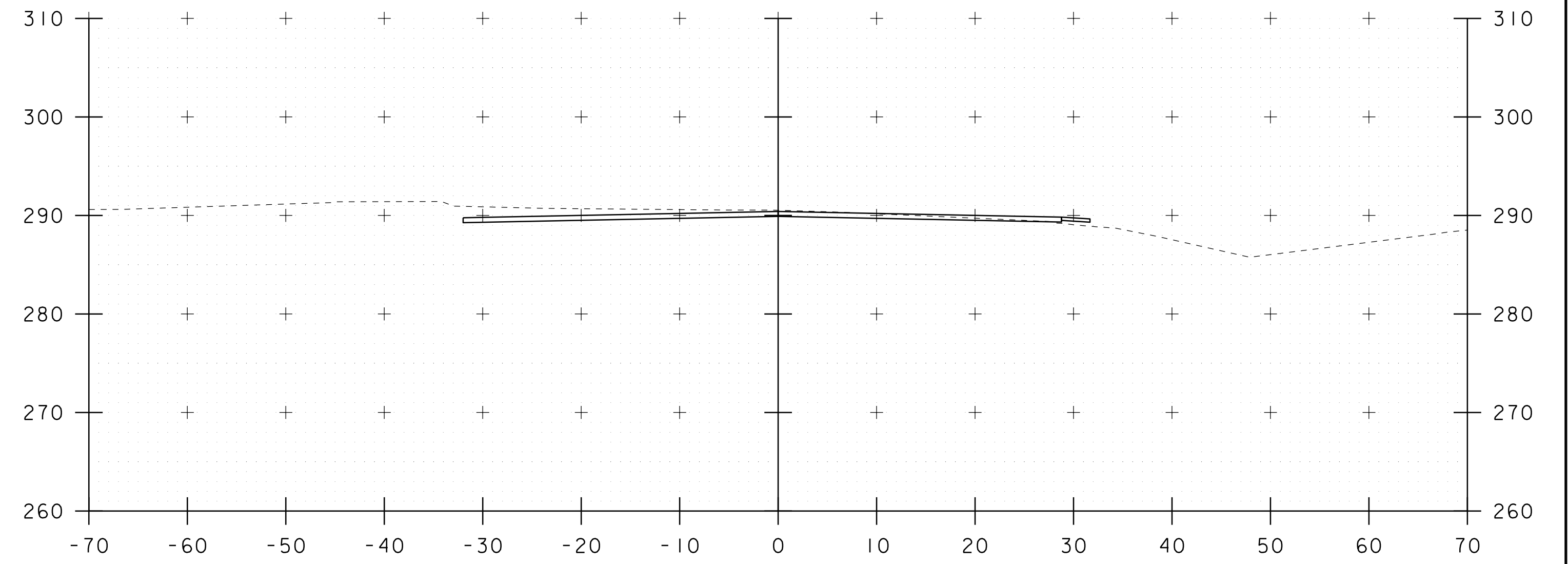

127+75

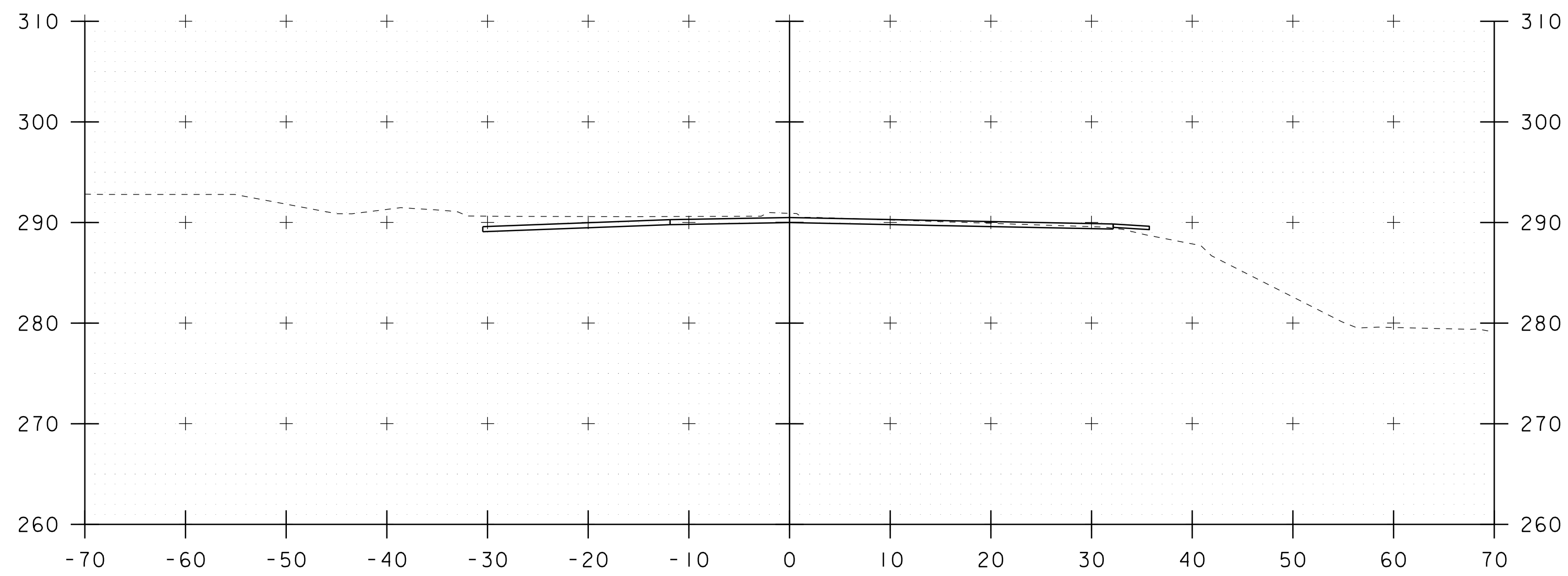

127+00

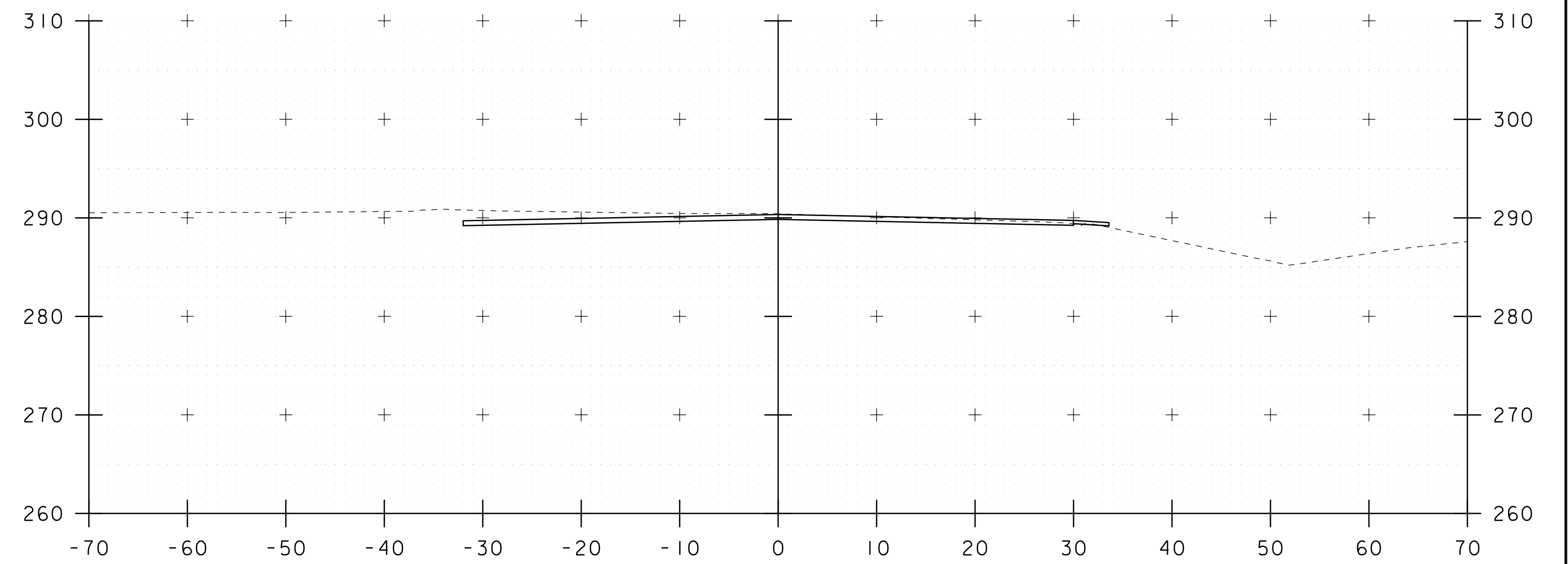

127+50

STA. 127+00 TO STA. 127+75

<b>PROJECT NAME:</b> ESSEX		<b>PLOT DATE:</b> 07-AUG-2017	
<b>PROJECT NUMBER:</b> BF 5400(9)		<b>DRAWN BY:</b> G. DARGAN	
<b>FILE NAME:</b> ppms#/Section/-----dgn		<b>DESIGNED BY:</b> G. DARGAN	
<b>PROJECT LEADER:</b> R. YOUNG		<b>CHECKED BY:</b> -----	
<b>MAINLINE CROSS SECTIONS 4</b>		<b>SHEET 16 OF 27</b>	

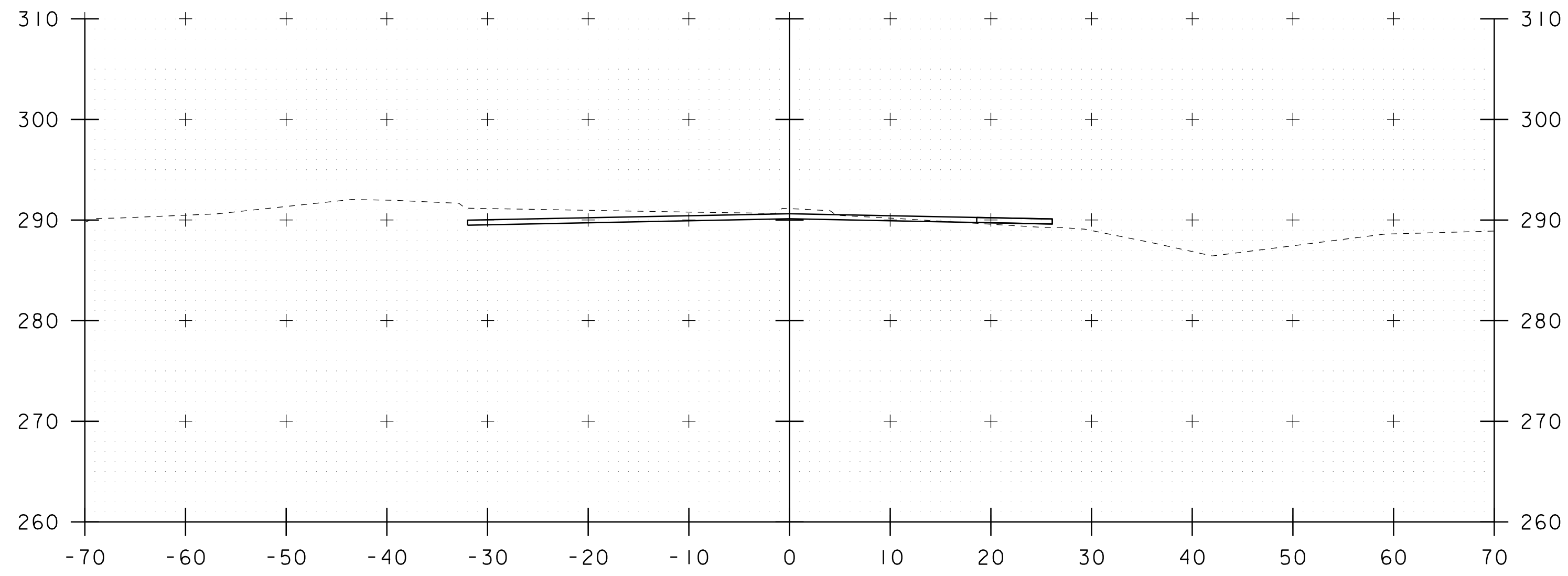

128+25

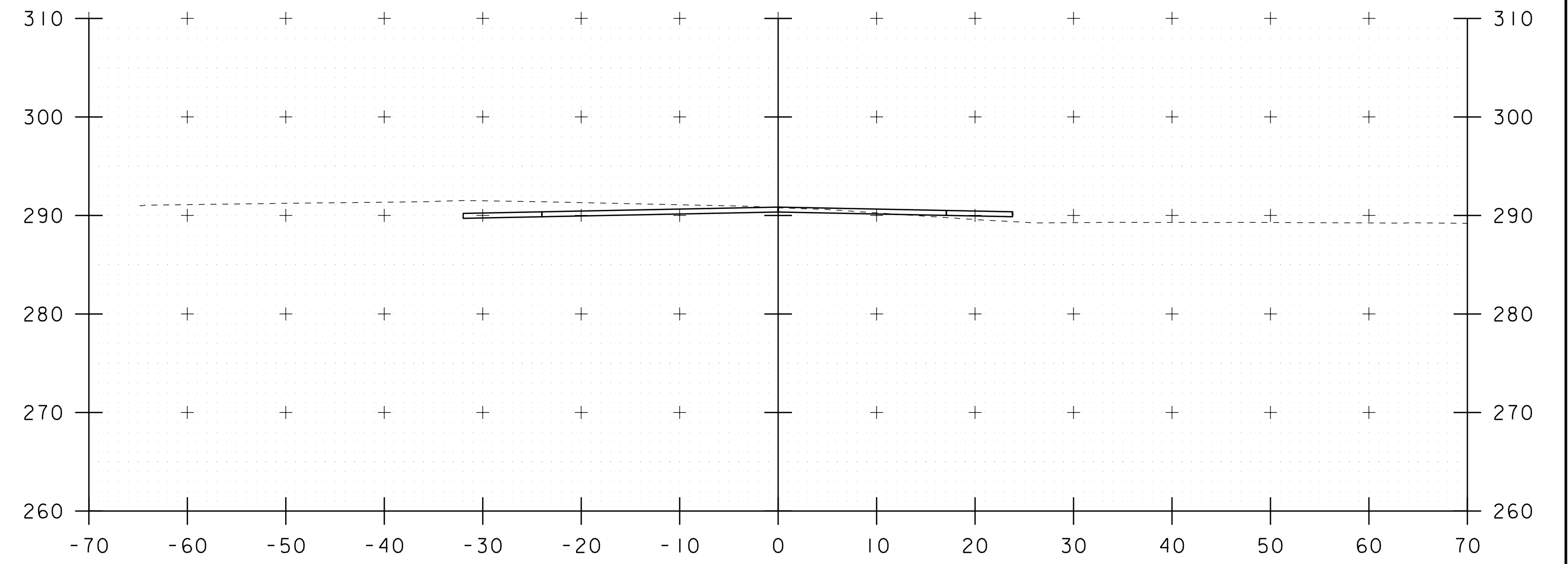

128+75

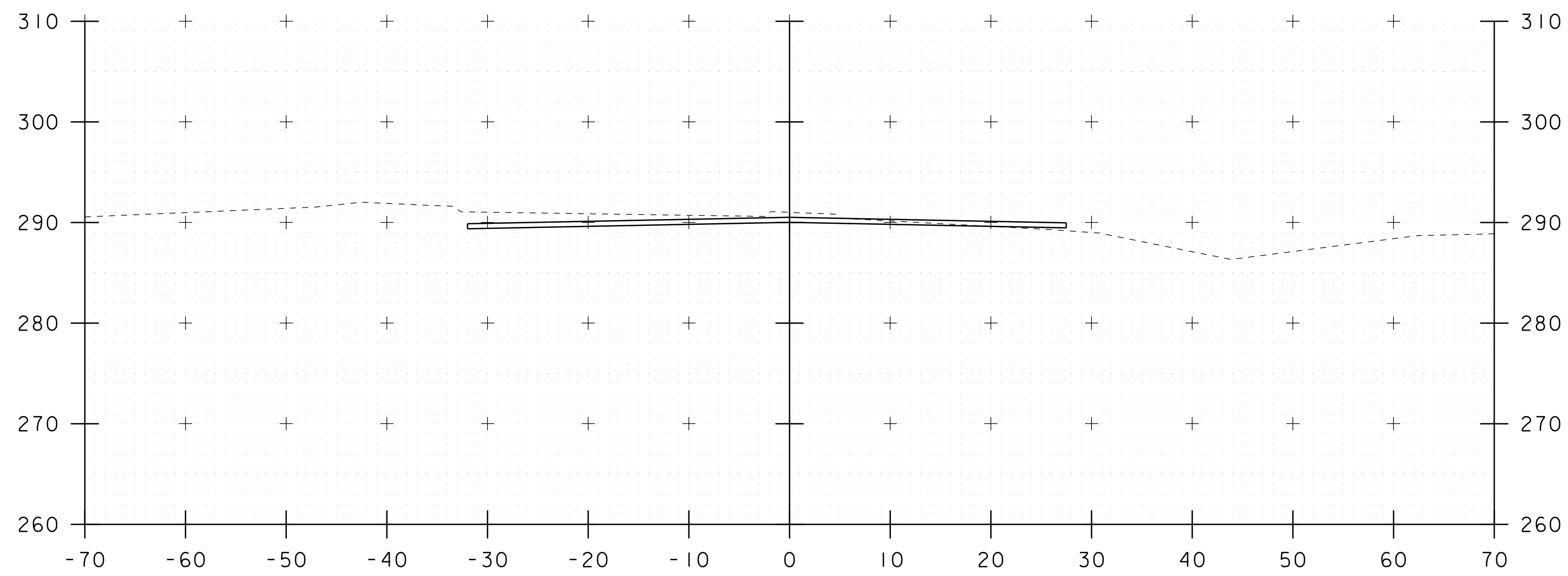

128+00

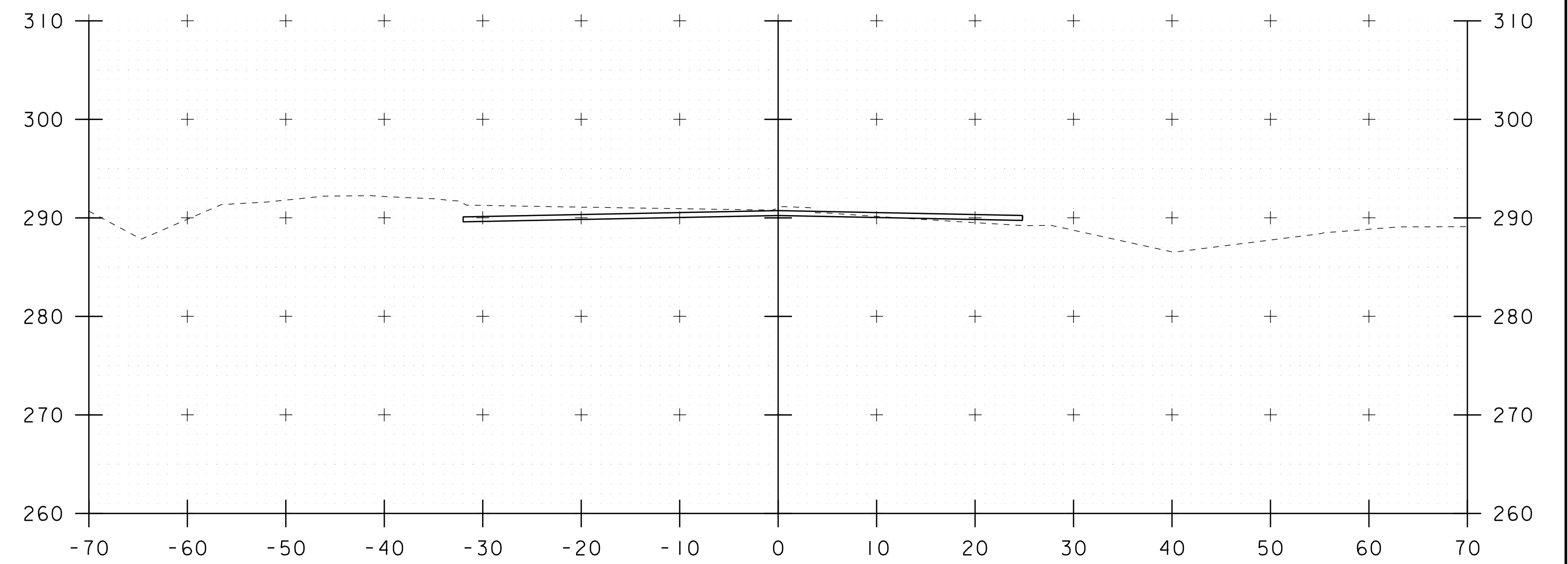

128+50

STA. 128+00 TO STA. 128+75

<b>PROJECT NAME:</b> ESSEX		<b>PLOT DATE:</b> 07-AUG-2017	
<b>PROJECT NUMBER:</b> BF 5400(9)		<b>DRAWN BY:</b> G. DARGAN	
<b>FILE NAME:</b> s13d654xs.dgn		<b>DESIGNED BY:</b> G. DARGAN	
<b>PROJECT LEADER:</b> R. YOUNG		<b>CHECKED BY:</b> -----	
<b>MAINLINE CROSS SECTIONS 5</b>		<b>SHEET 17 OF 27</b>	

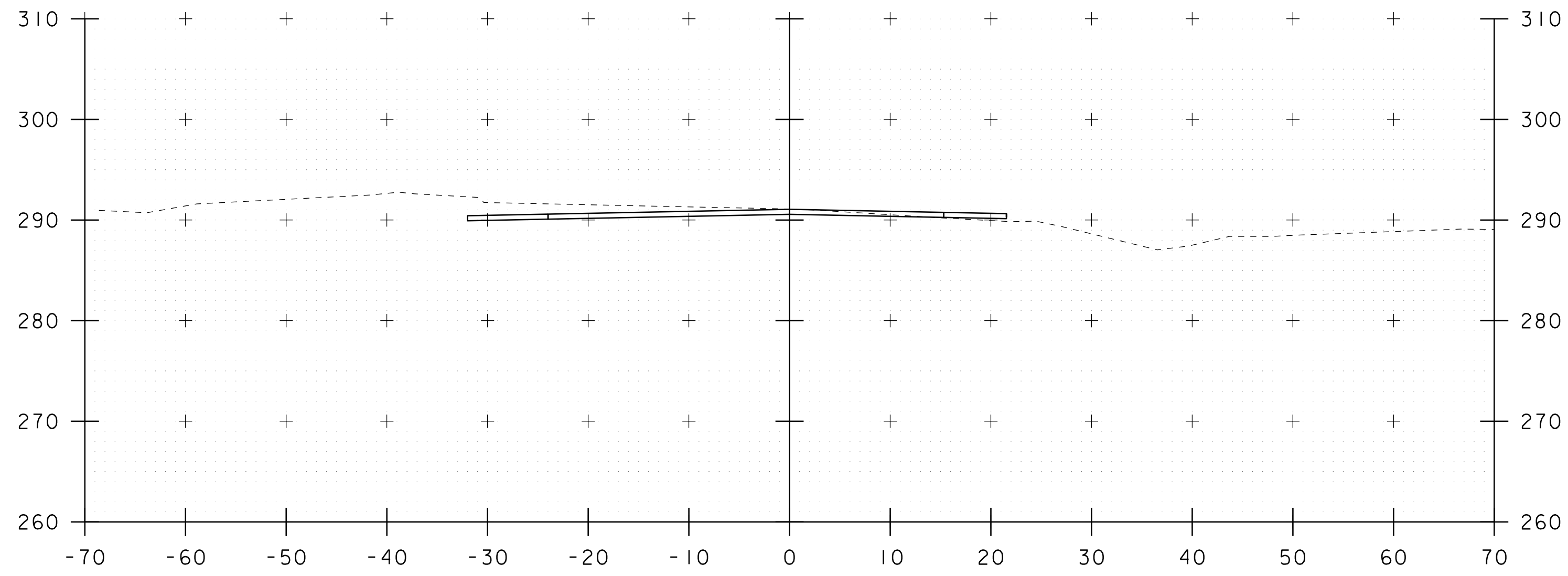

129+25

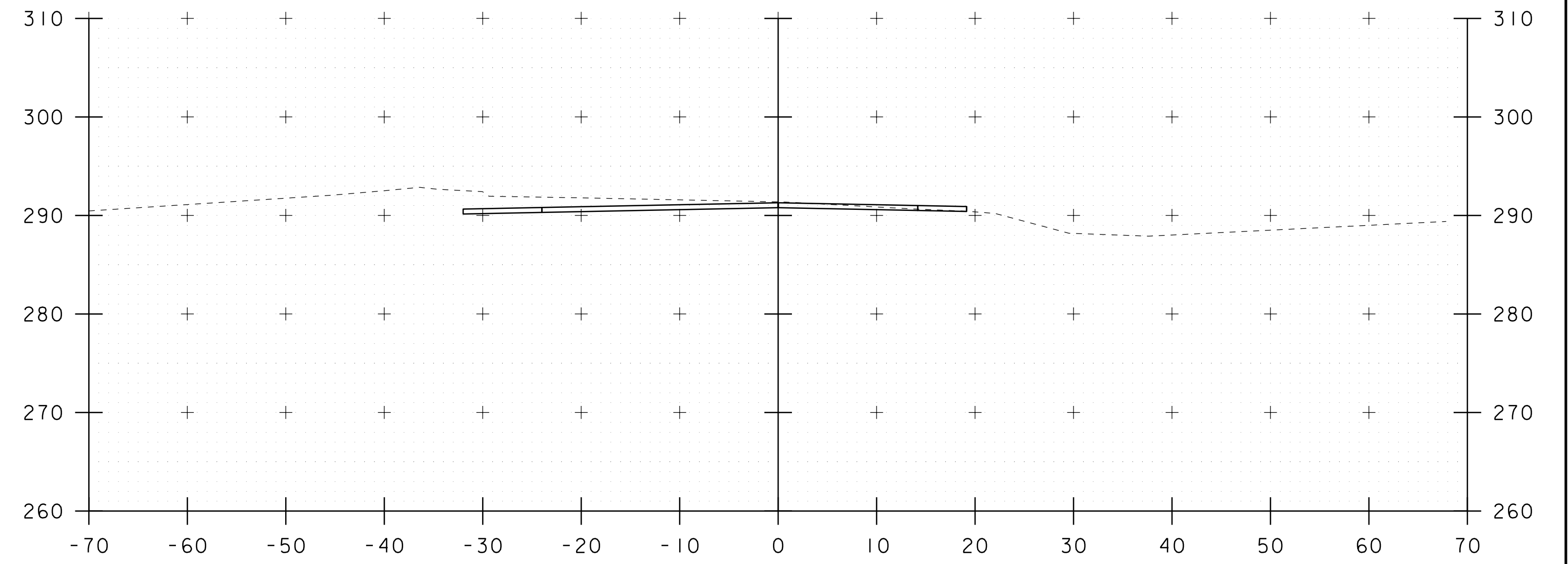

129+75

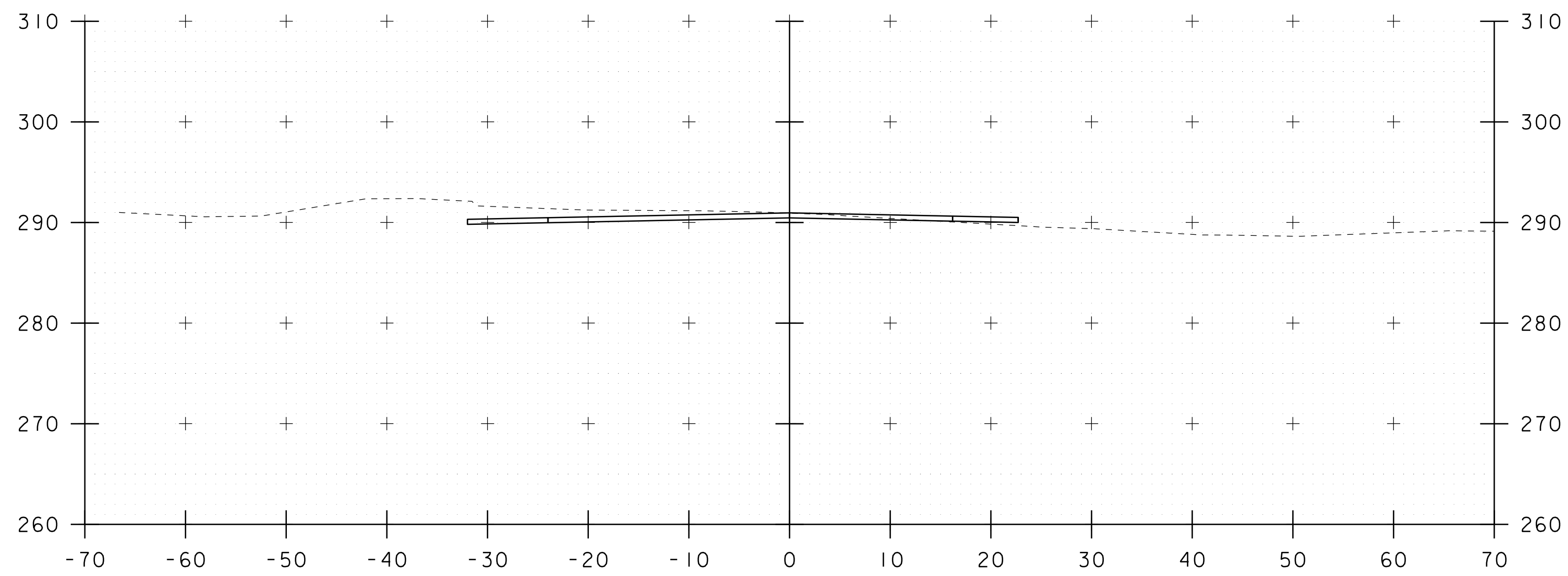

129+00

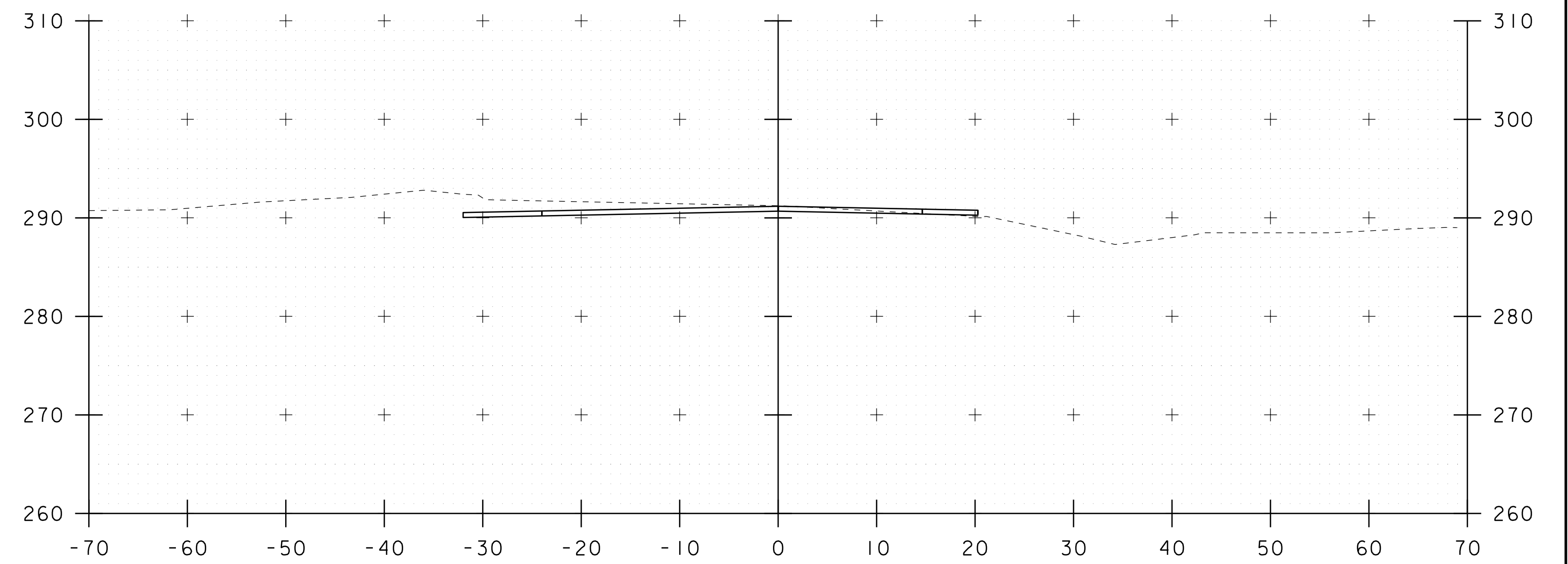

129+50

STA. 129+00 TO STA. 129+75

<b>PROJECT NAME:</b> ESSEX		<b>PLOT DATE:</b> 07-AUG-2017	
<b>PROJECT NUMBER:</b> BF 5400(9)		<b>DRAWN BY:</b> G. DARGAN	
<b>FILE NAME:</b> sl3d654xs.dgn	<b>DESIGNED BY:</b> G. DARGAN	<b>CHECKED BY:</b> -----	<b>SHEET</b> 18 <b>OF</b> 27
<b>MAINLINE CROSS SECTIONS 6</b>			



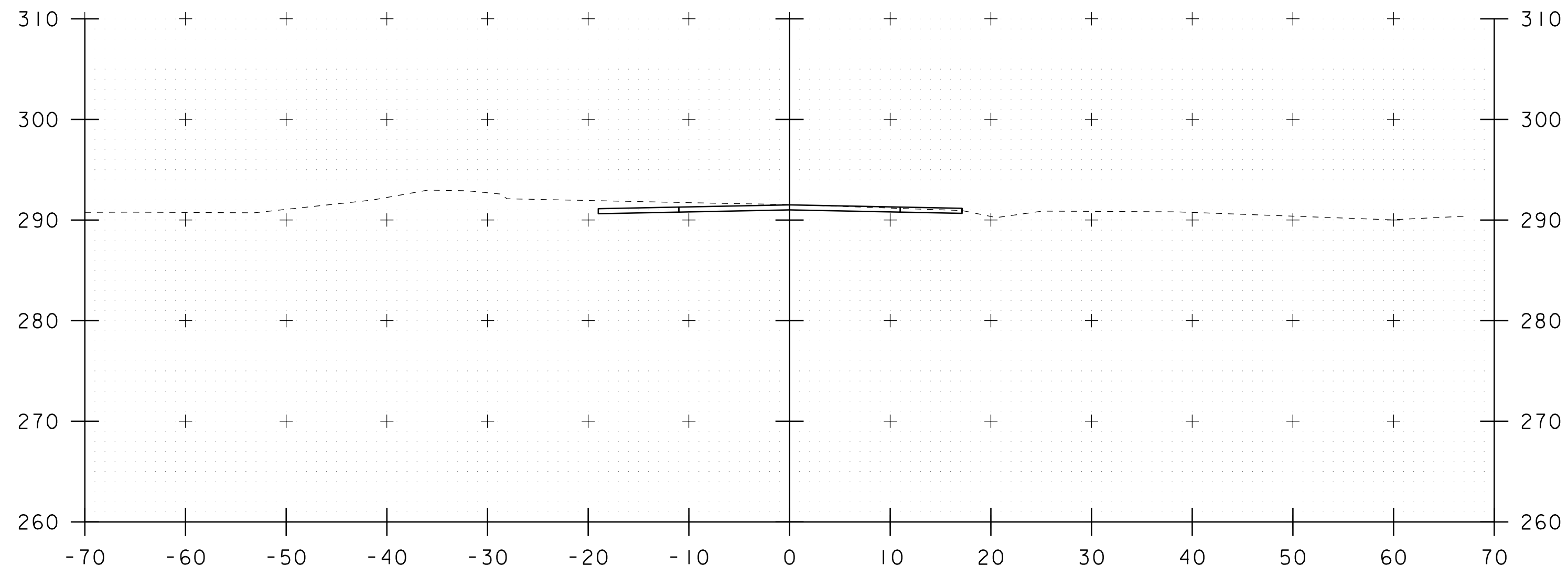

130+25

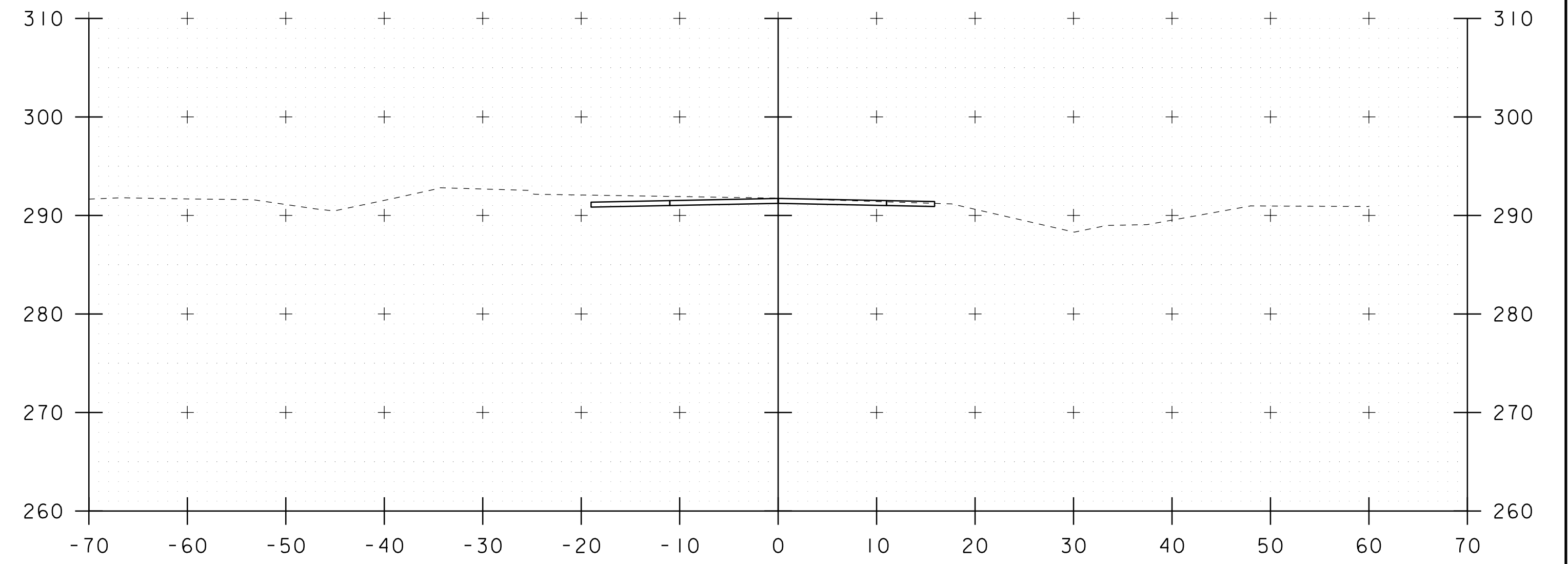

130+75

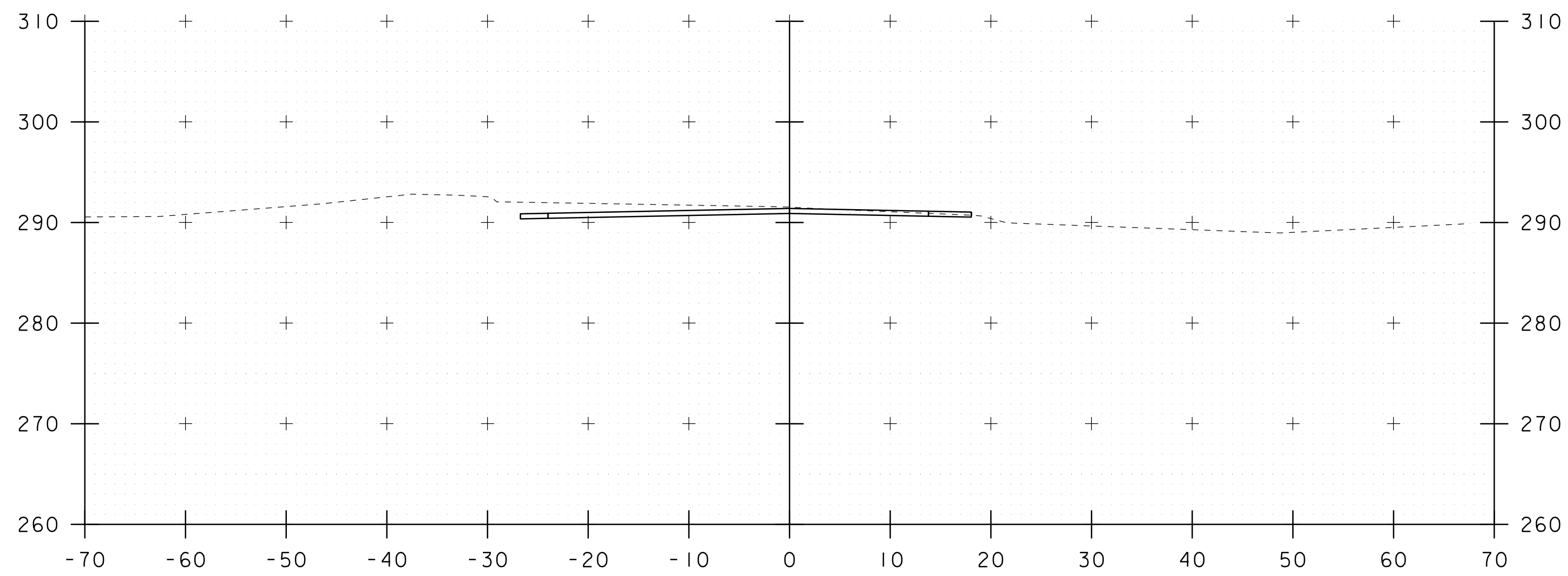

130+00

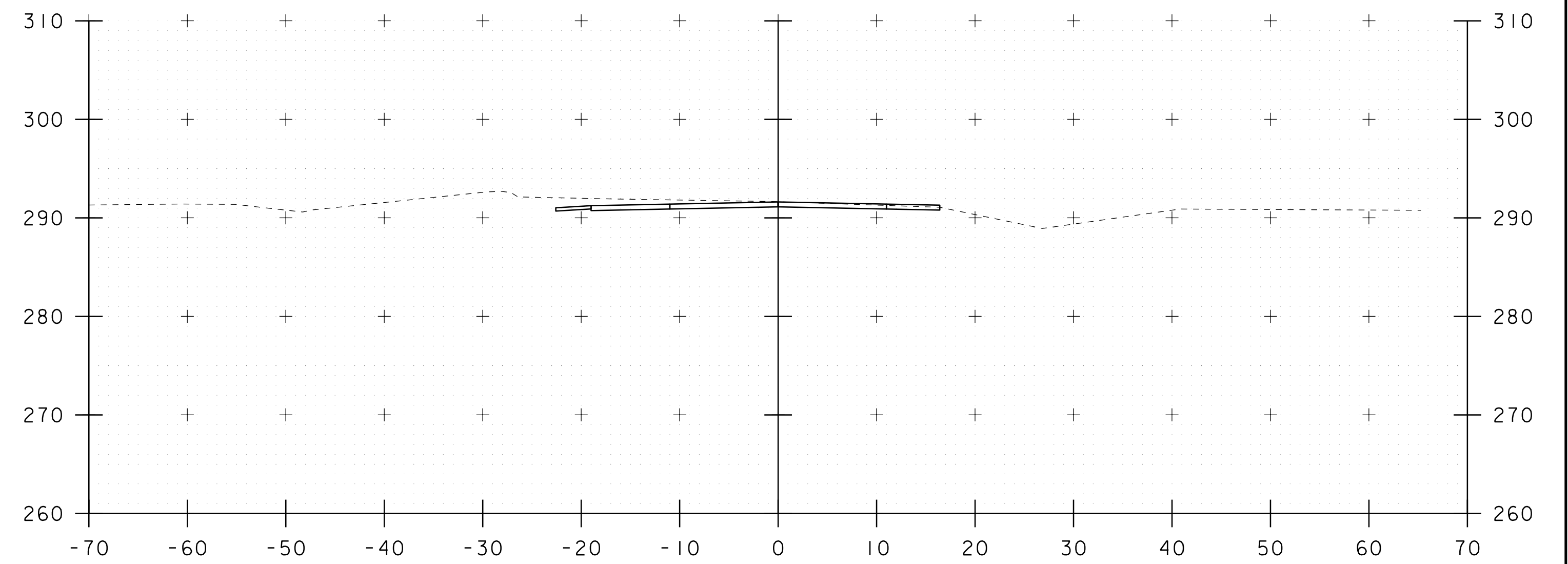

130+50

STA. 130+00 TO STA. 130+75

<b>PROJECT NAME:</b> ESSEX		<b>PLOT DATE:</b> 07-AUG-2017	
<b>PROJECT NUMBER:</b> BF 5400(9)		<b>DRAWN BY:</b> G. DARGAN	
<b>FILE NAME:</b> sl3d654xs.dgn		<b>DESIGNED BY:</b> G. DARGAN	
<b>PROJECT LEADER:</b> R. YOUNG		<b>CHECKED BY:</b> -----	
<b>MAINLINE CROSS SECTIONS 6</b>		<b>SHEET 19 OF 27</b>	

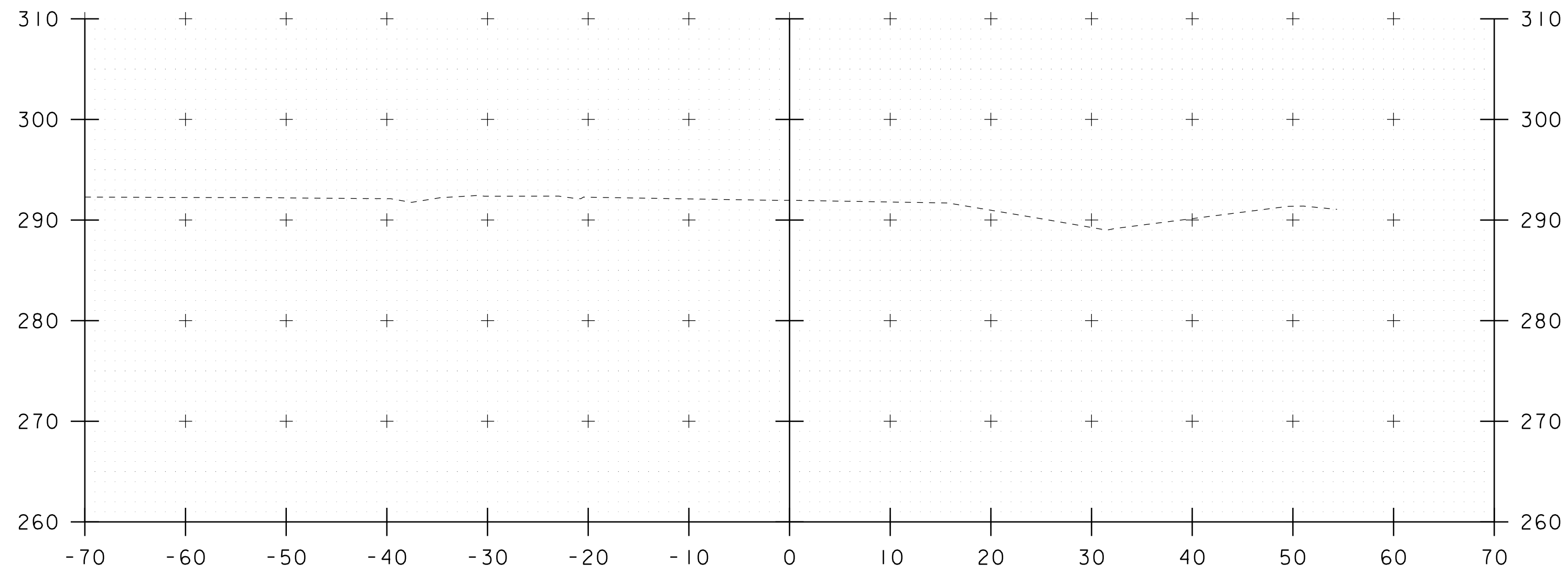

131+25

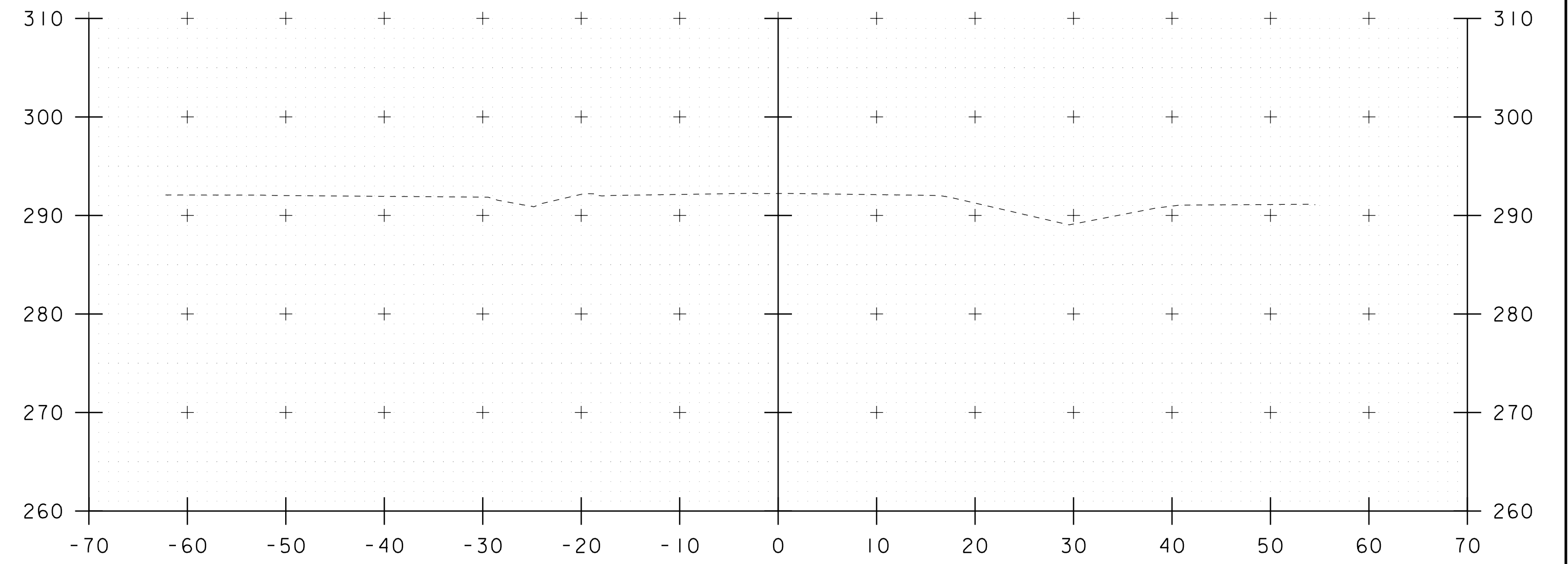

131+75

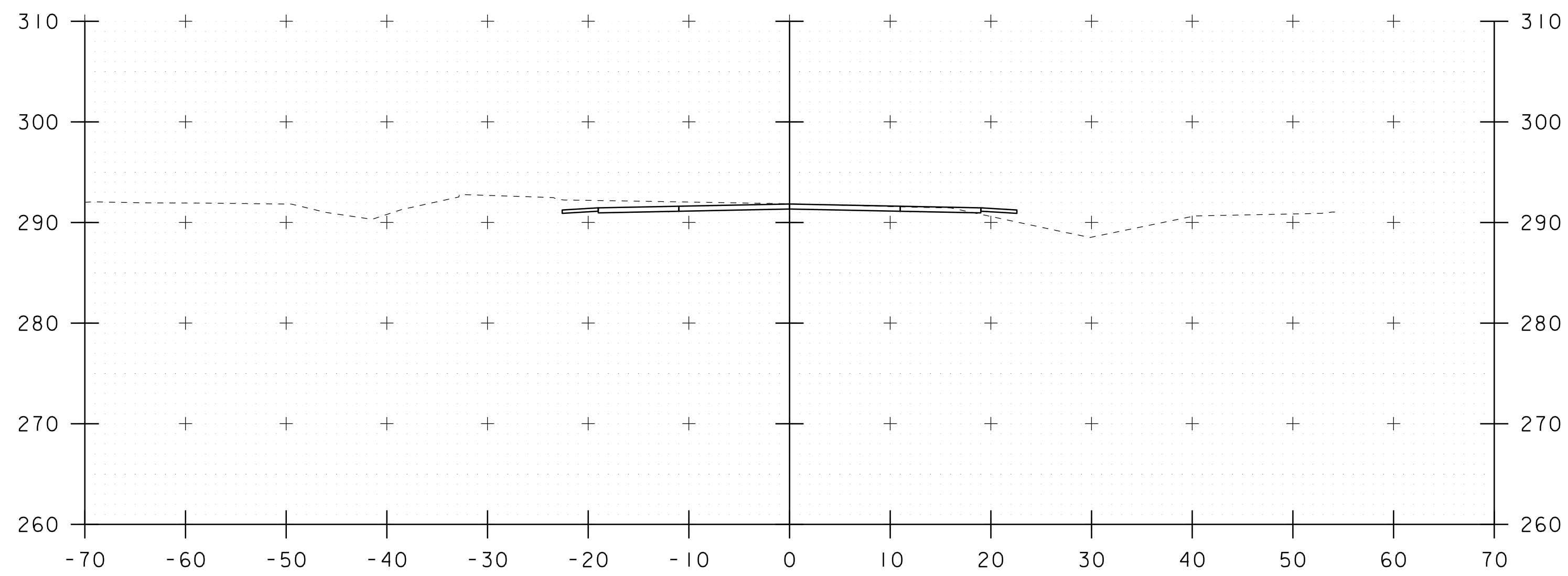

131+00

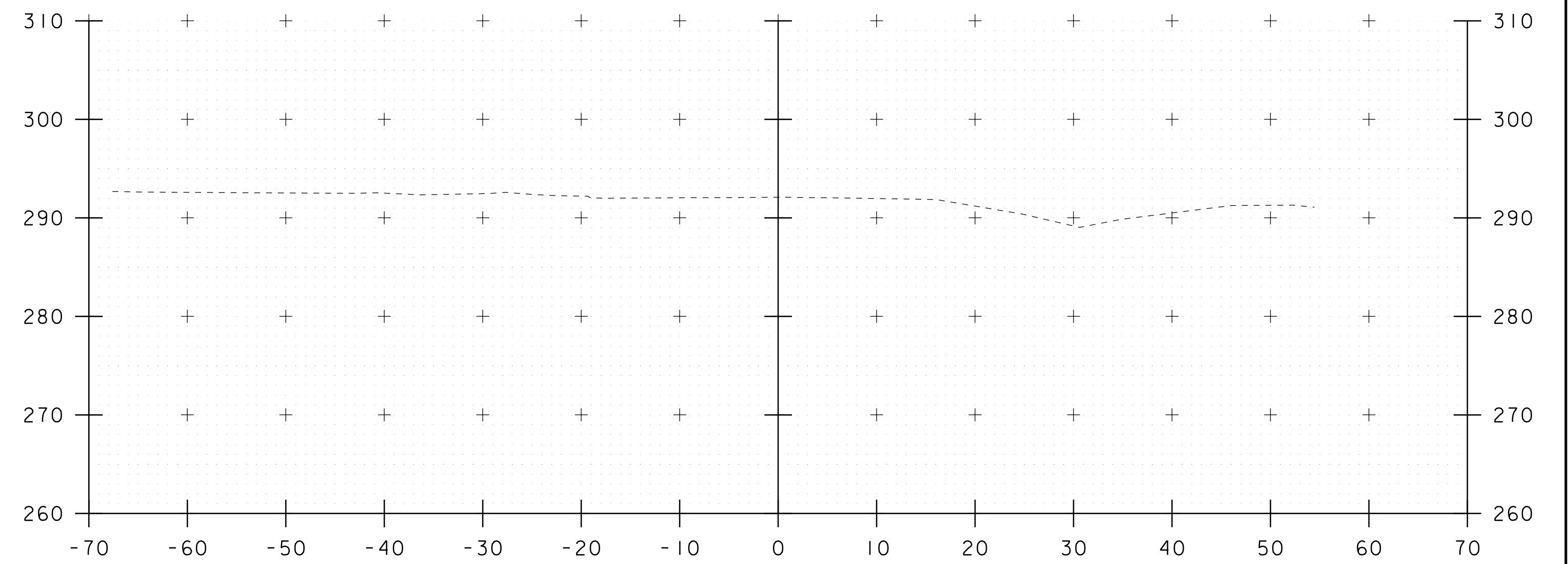

131+50

STA. 131+00 TO STA. 131+75

<b>PROJECT NAME:</b> ESSEX		<b>PLOT DATE:</b> 07-AUG-2017	
<b>PROJECT NUMBER:</b> BF 5400(9)		<b>DRAWN BY:</b> G. DARGAN	
<b>FILE NAME:</b> sl3d654xs.dgn		<b>DESIGNED BY:</b> G. DARGAN	
<b>PROJECT LEADER:</b> R. YOUNG		<b>CHECKED BY:</b> -----	
<b>MAINLINE CROSS SECTIONS 7</b>		<b>SHEET 20 OF 27</b>	

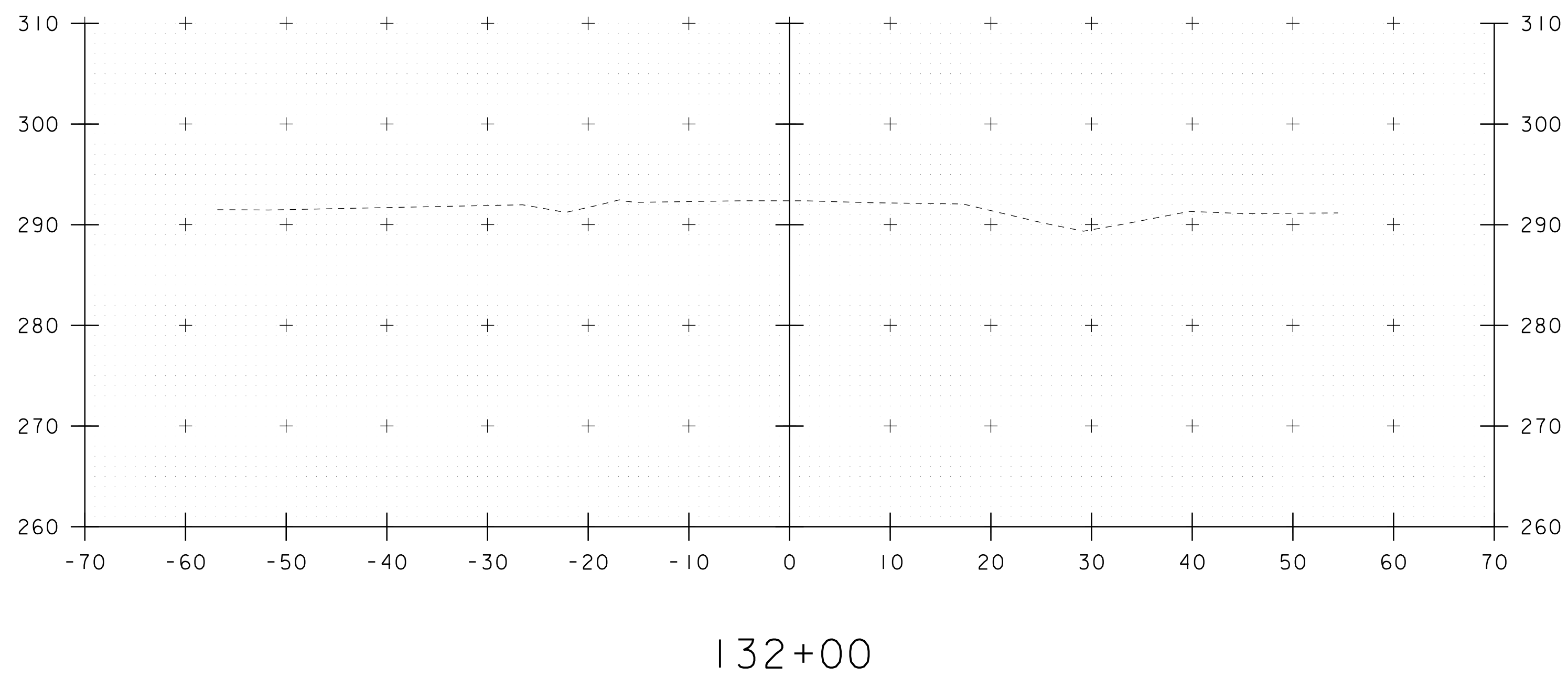

STA. 132+00 TO STA. 132+00

**PROJECT NAME:** ESSEX  
**PROJECT NUMBER:** BF 5400(9)

**FILE NAME:** sl3d654xs.dgn  
**PROJECT LEADER:** R. YOUNG  
**DESIGNED BY:** G. DARGAN  
 MAINLINE CROSS SECTIONS 8

**PLOT DATE:** 07-AUG-2017  
**DRAWN BY:** G. DARGAN  
**CHECKED BY:** -----  
**SHEET** 21 **OF** 27

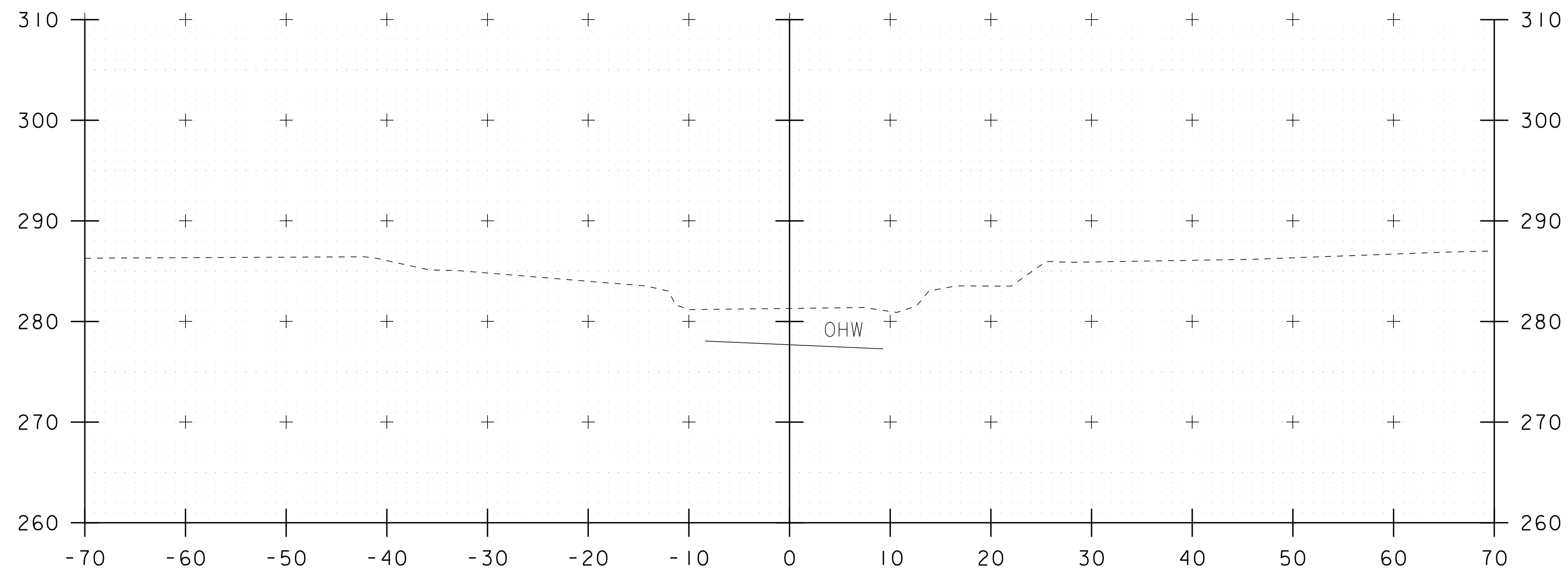

51+50

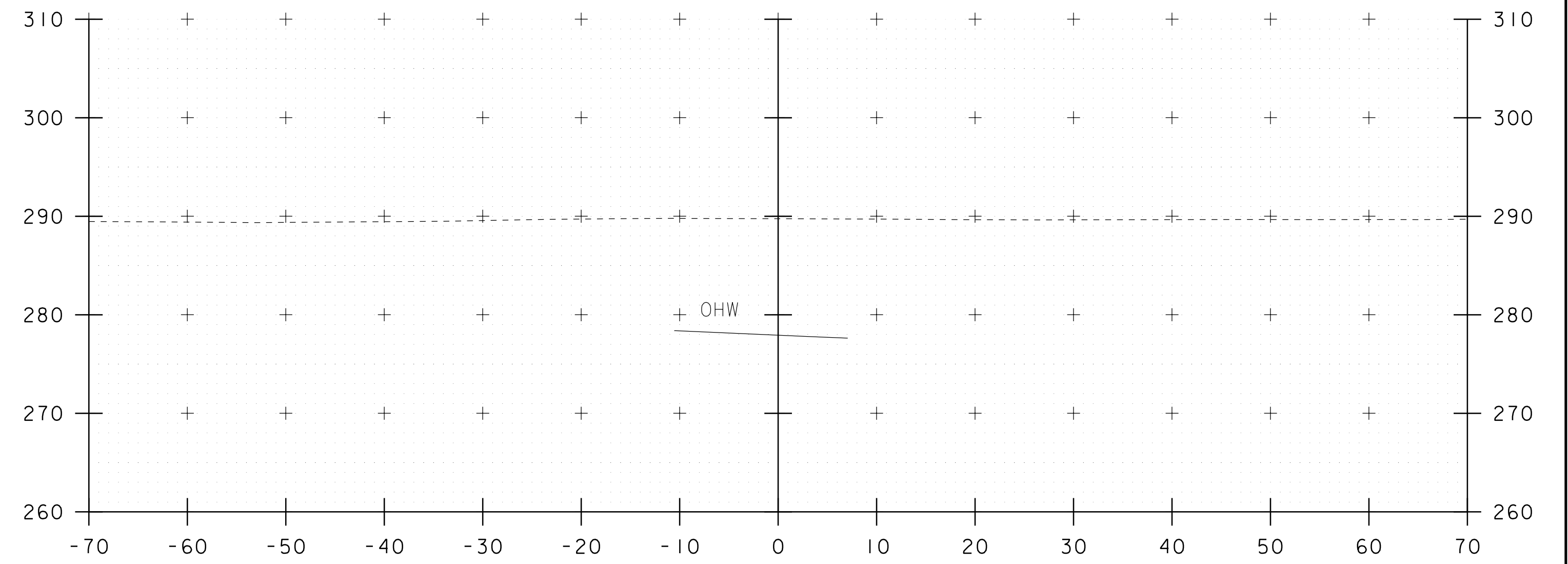

51+70

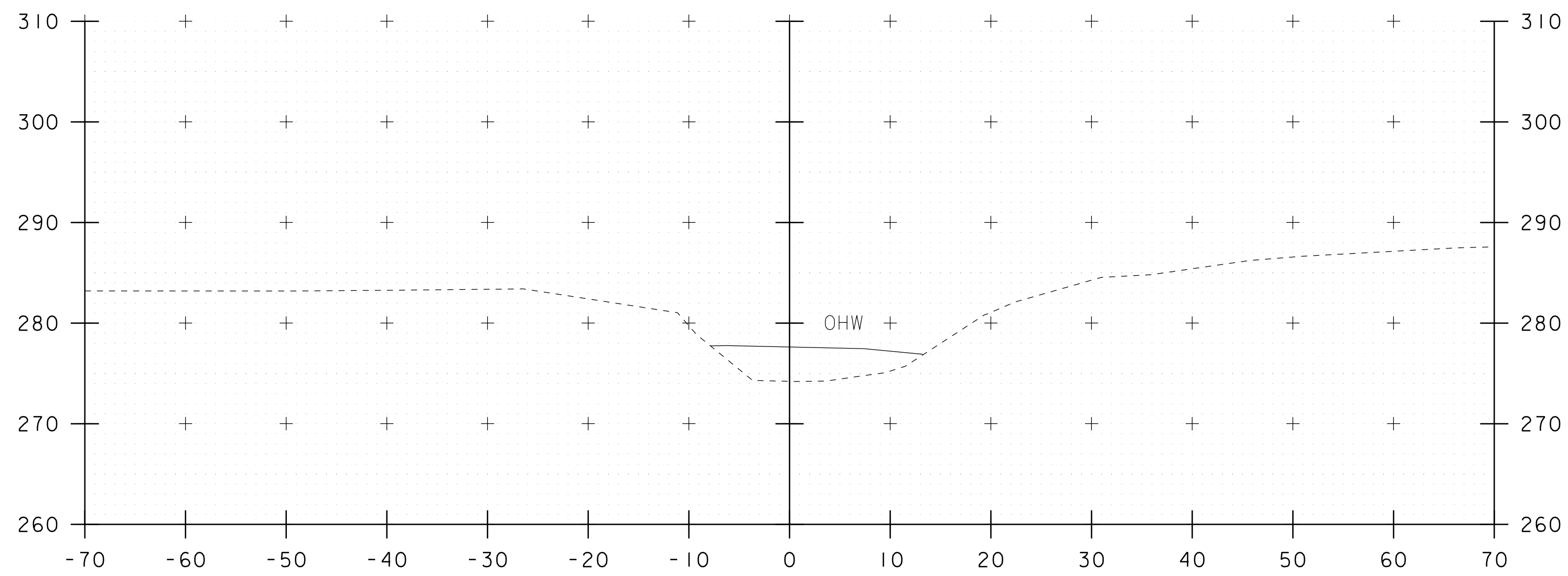

51+25

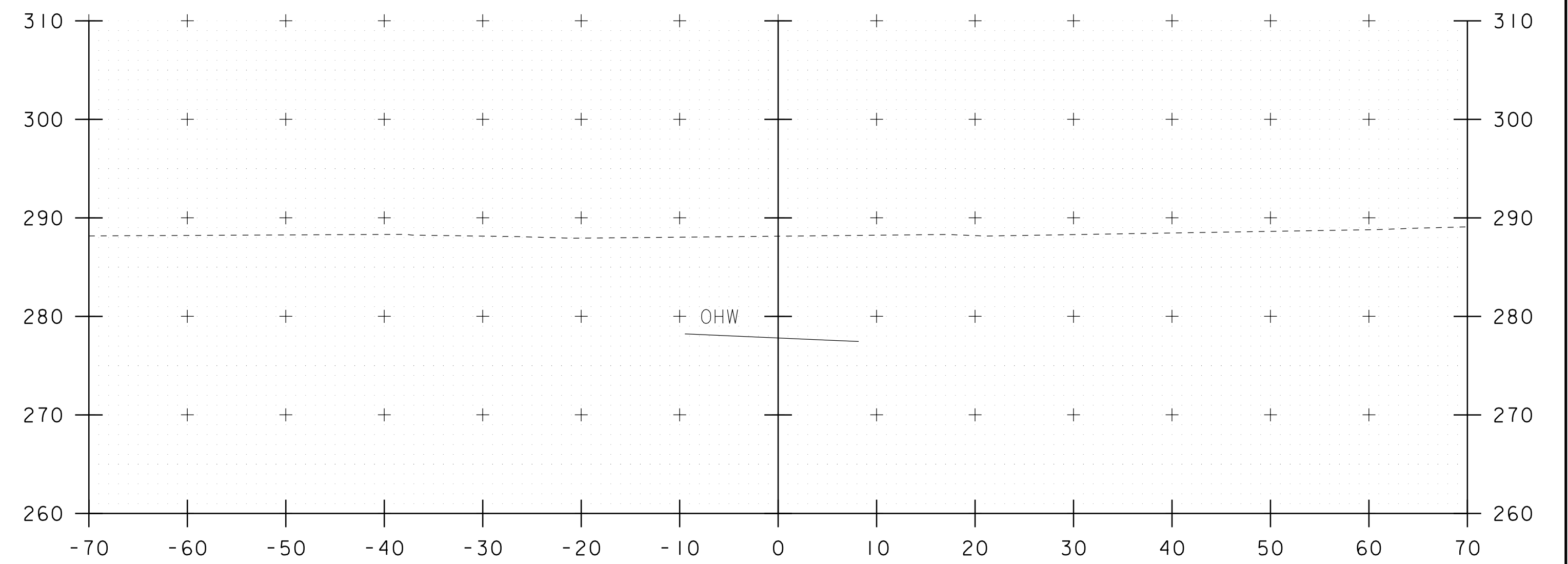

51+60

STA. 51+25 TO STA. 51+70

<b>PROJECT NAME:</b> ESSEX		<b>PLOT DATE:</b> 07-AUG-2017	
<b>PROJECT NUMBER:</b> BF 5400(9)		<b>DRAWN BY:</b> G. DARGAN	
<b>FILE NAME:</b> s13d654xs.dgn		<b>DESIGNED BY:</b> G. DARGAN	
<b>PROJECT LEADER:</b> R. YOUNG		<b>CHECKED BY:</b> -----	
<b>CHANNEL CROSS SECTIONS 1</b>		<b>SHEET 22 OF 27</b>	

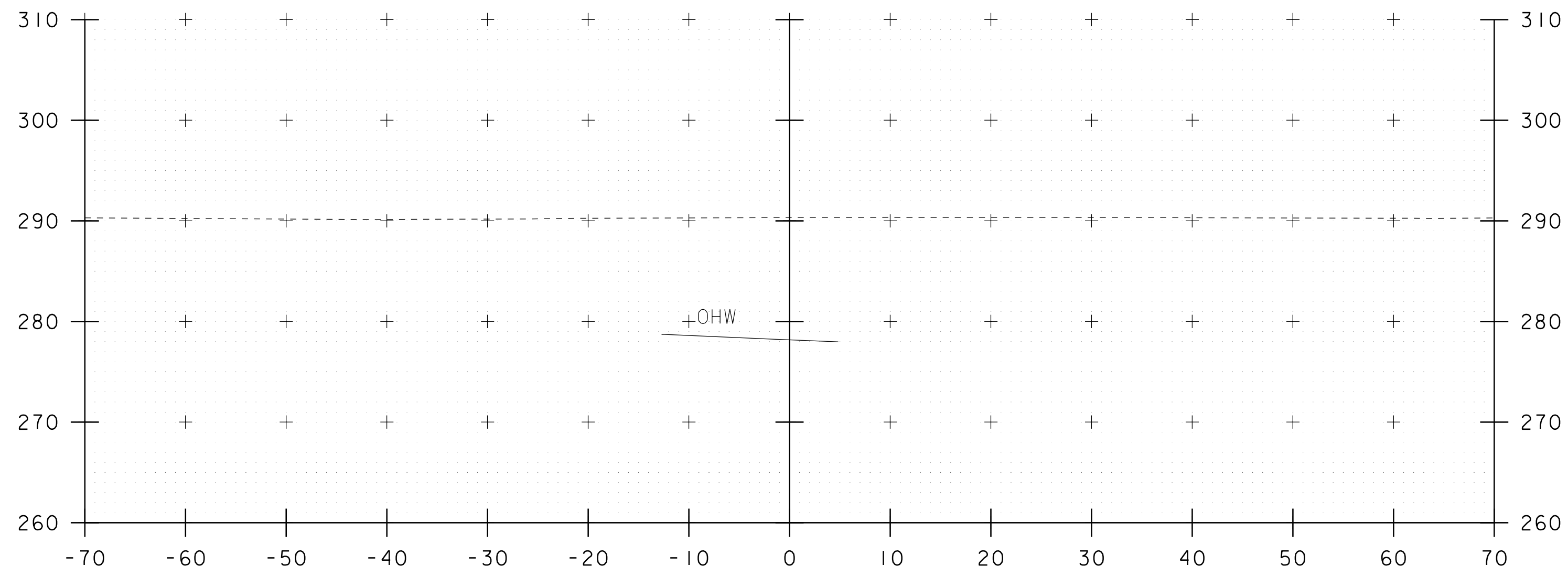

51+90

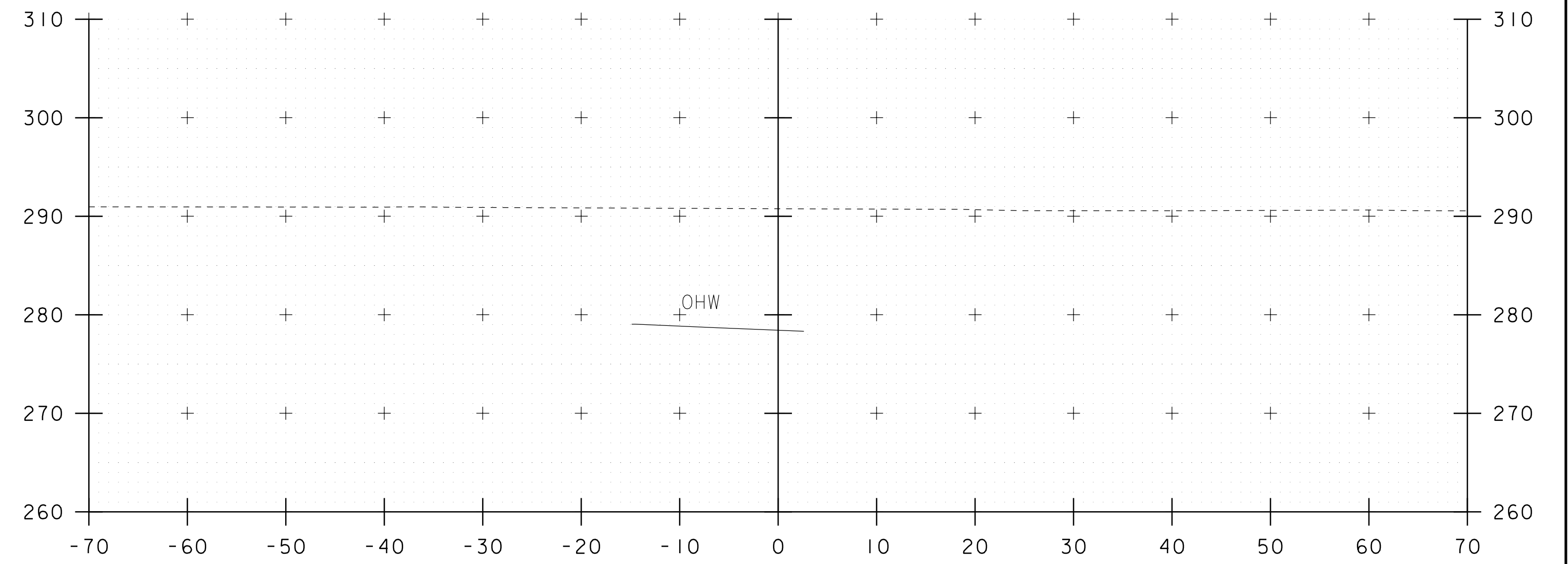

52+10

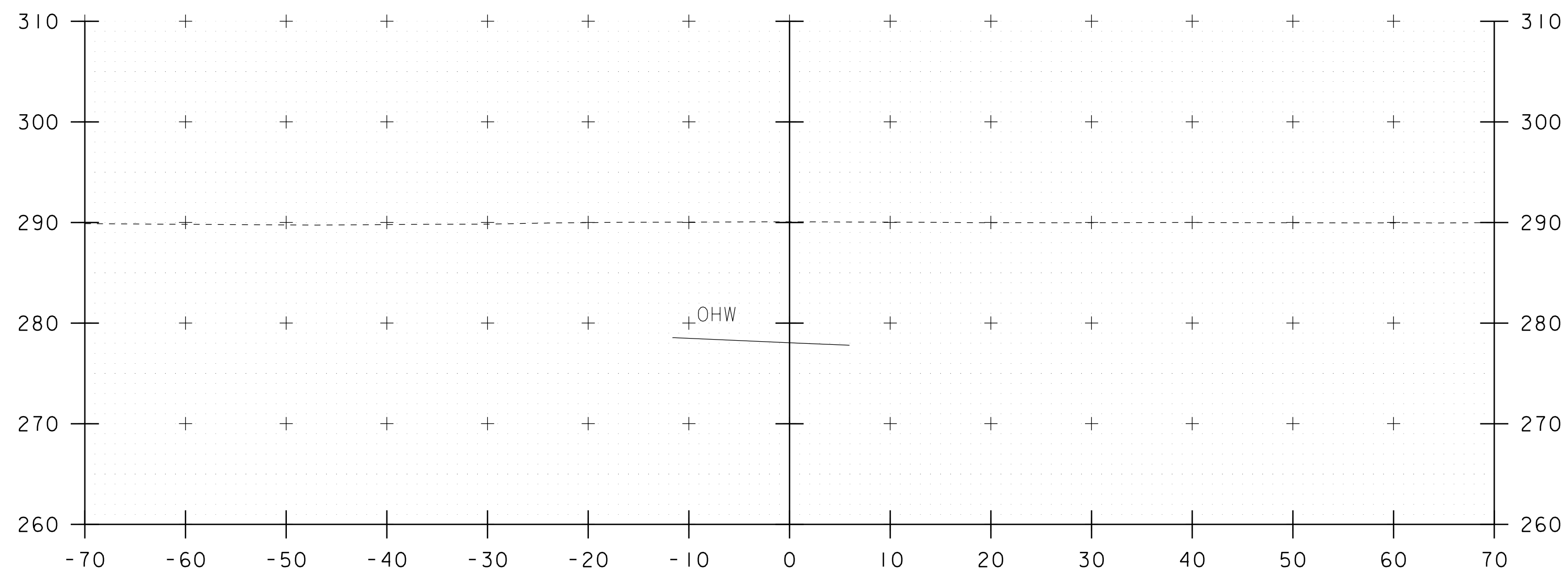

51+80

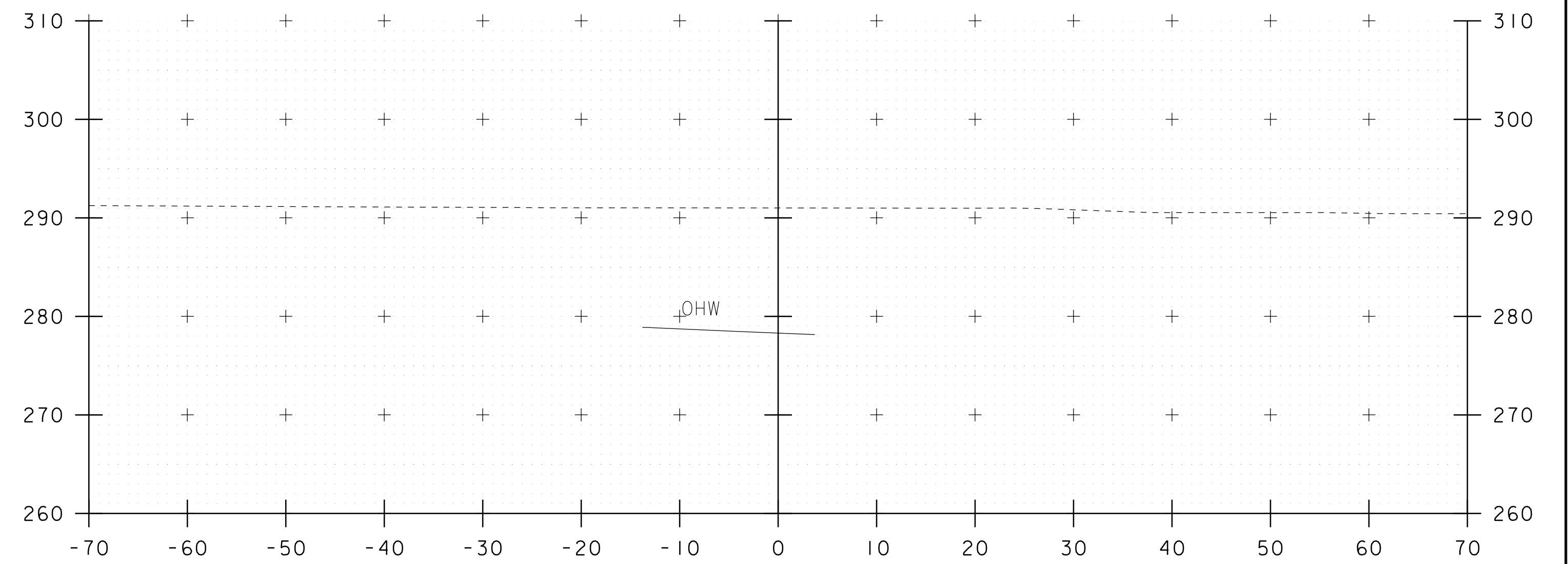

52+00

STA. 51+80 TO STA. 52+10

<b>PROJECT NAME:</b> ESSEX		<b>PLOT DATE:</b> 07-AUG-2017	
<b>PROJECT NUMBER:</b> BF 5400 (9)		<b>DRAWN BY:</b> G. DARGAN	
<b>FILE NAME:</b> sl3d654xs.dgn		<b>DESIGNED BY:</b> G. DARGAN	
<b>PROJECT LEADER:</b> R. YOUNG		<b>CHECKED BY:</b> -----	
<b>CHANNEL CROSS SECTIONS 2</b>		<b>SHEET 23 OF 27</b>	



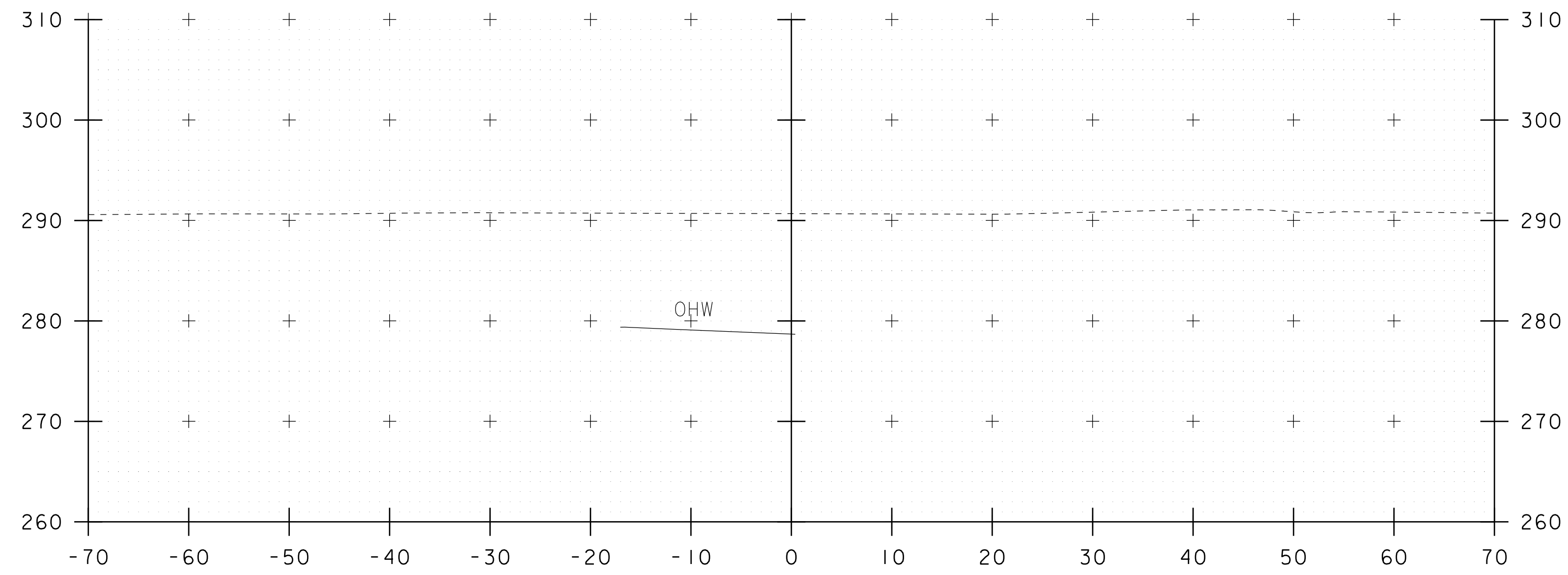

52+30

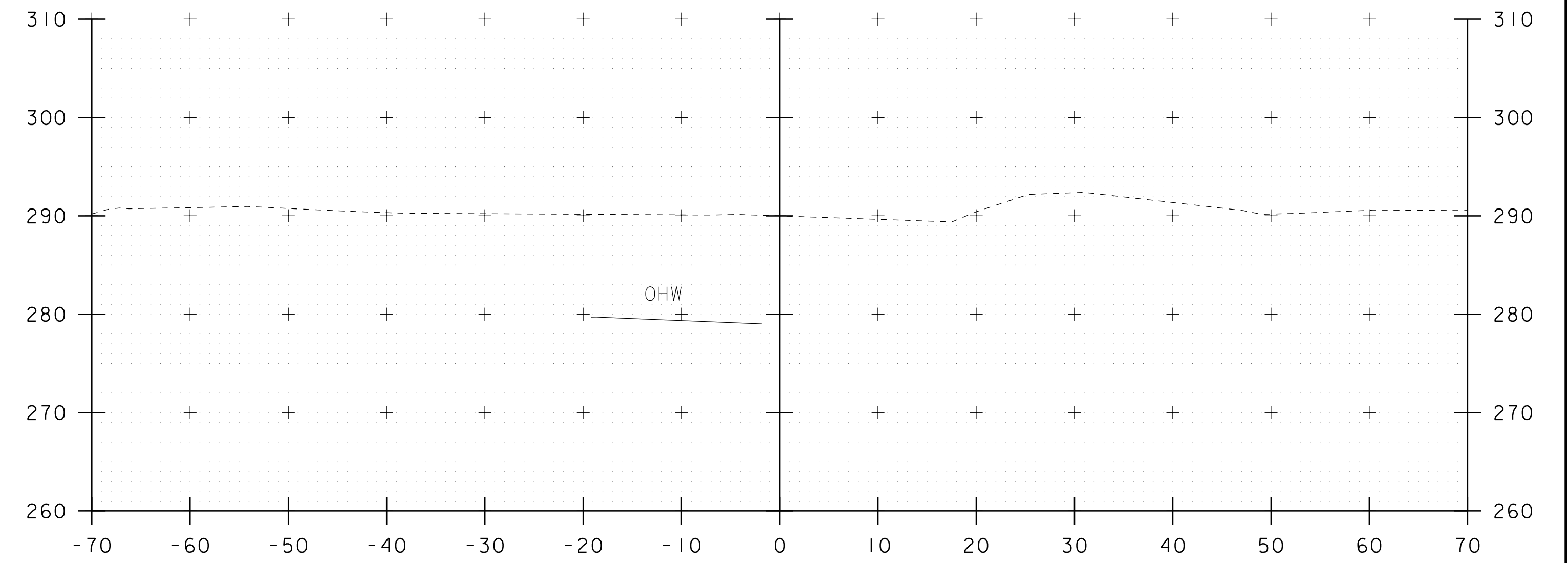

52+50

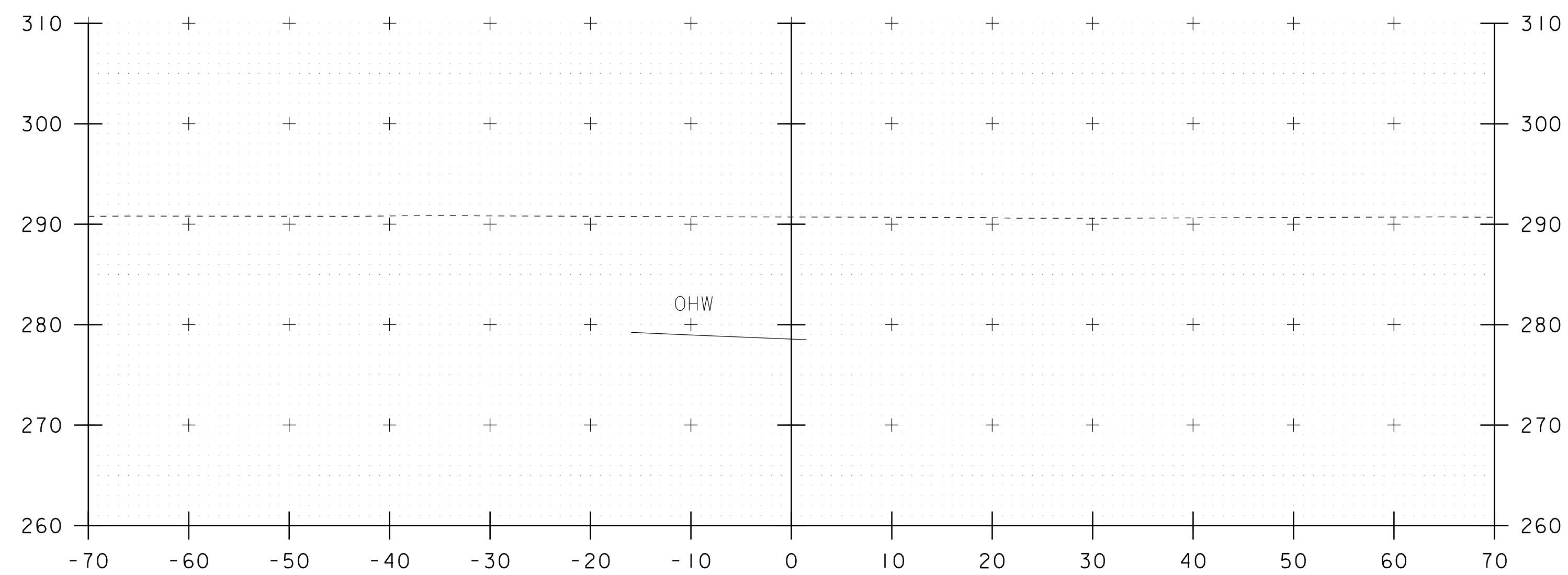

52+20

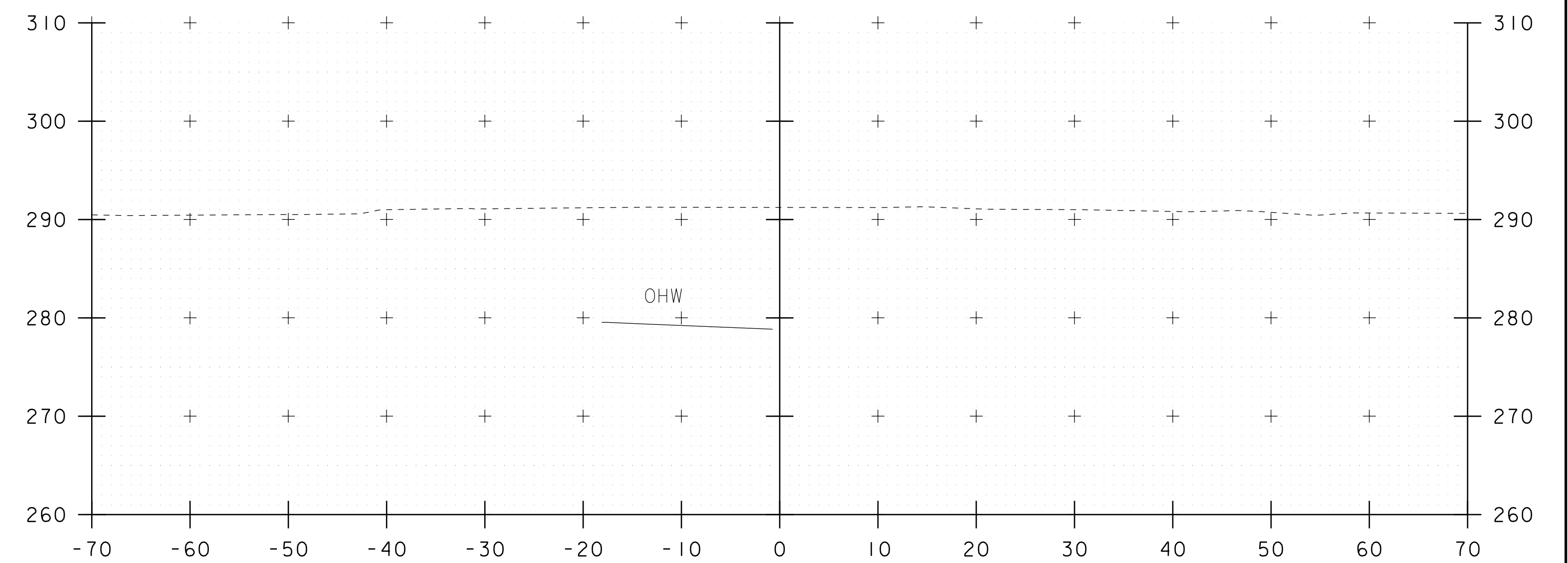

52+40

STA. 52+20 TO STA. 52+50

<b>PROJECT NAME:</b> ESSEX		<b>PLOT DATE:</b> 07-AUG-2017	
<b>PROJECT NUMBER:</b> BF 5400(9)		<b>DRAWN BY:</b> G. DARGAN	
<b>FILE NAME:</b> sl3d654xs.dgn		<b>DESIGNED BY:</b> G. DARGAN	
<b>PROJECT LEADER:</b> R. YOUNG		<b>CHECKED BY:</b> -----	
<b>CHANNEL CROSS SECTIONS 3</b>		<b>SHEET 24 OF 27</b>	

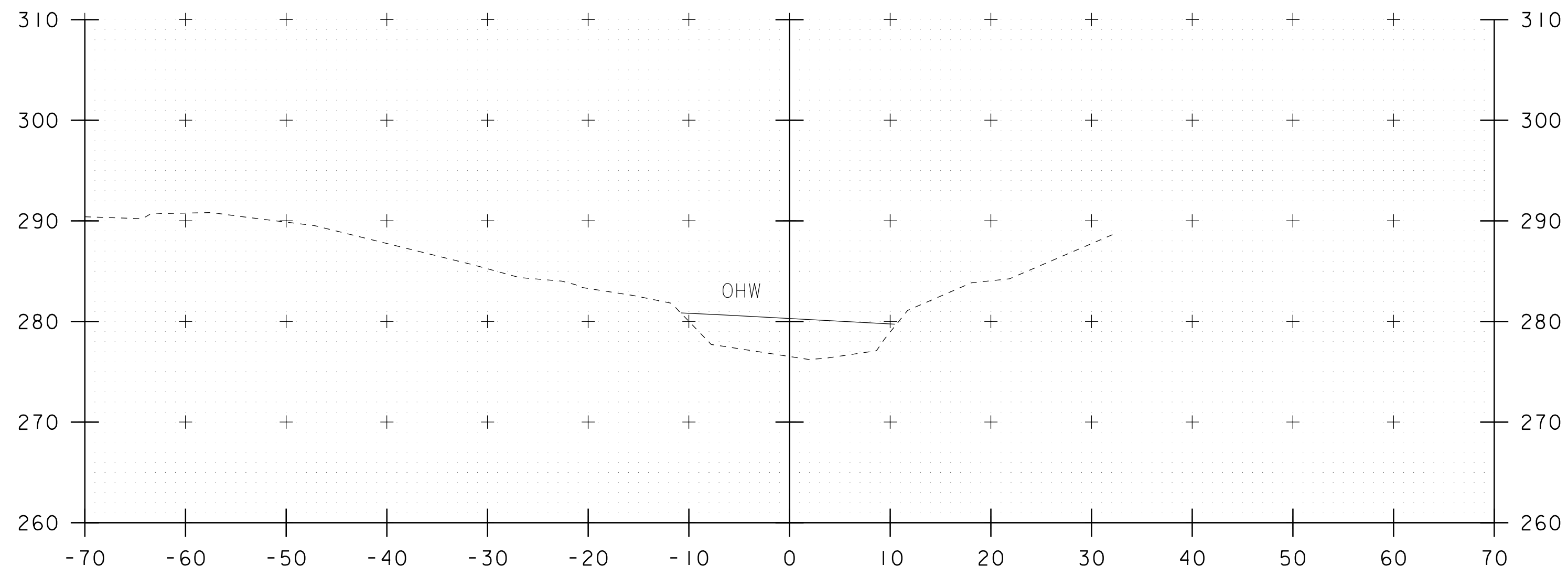

53+00

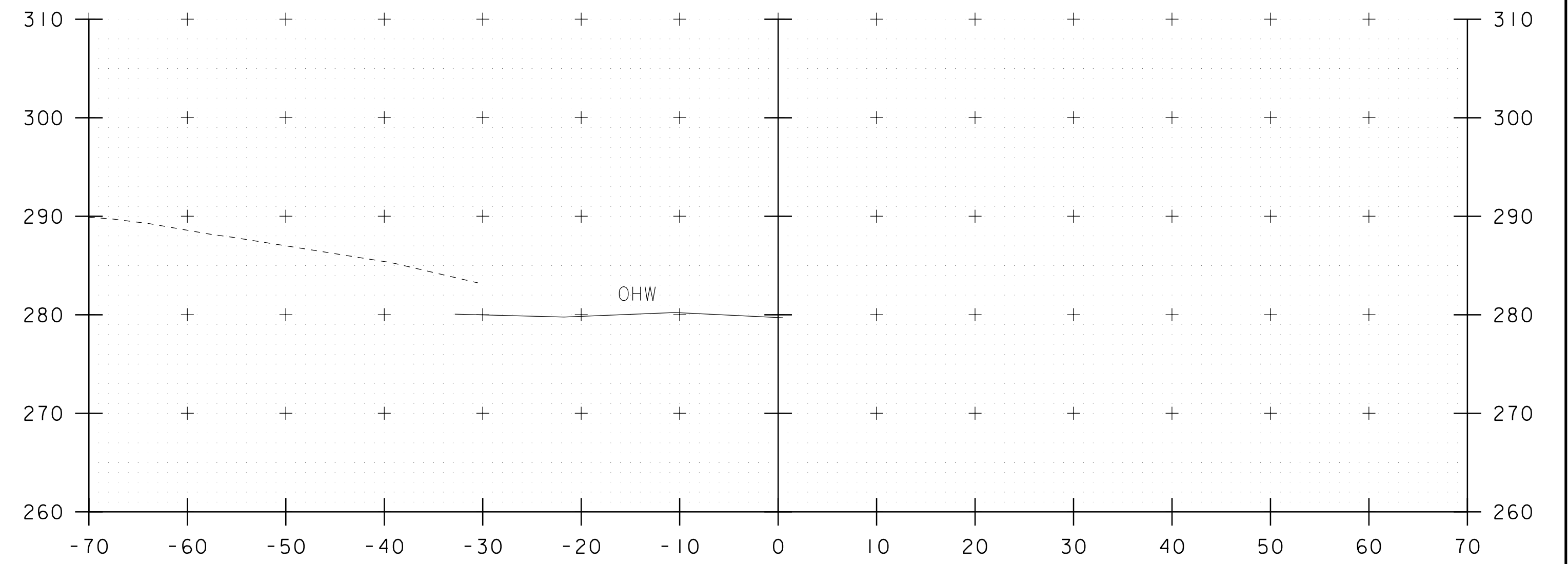

53+50

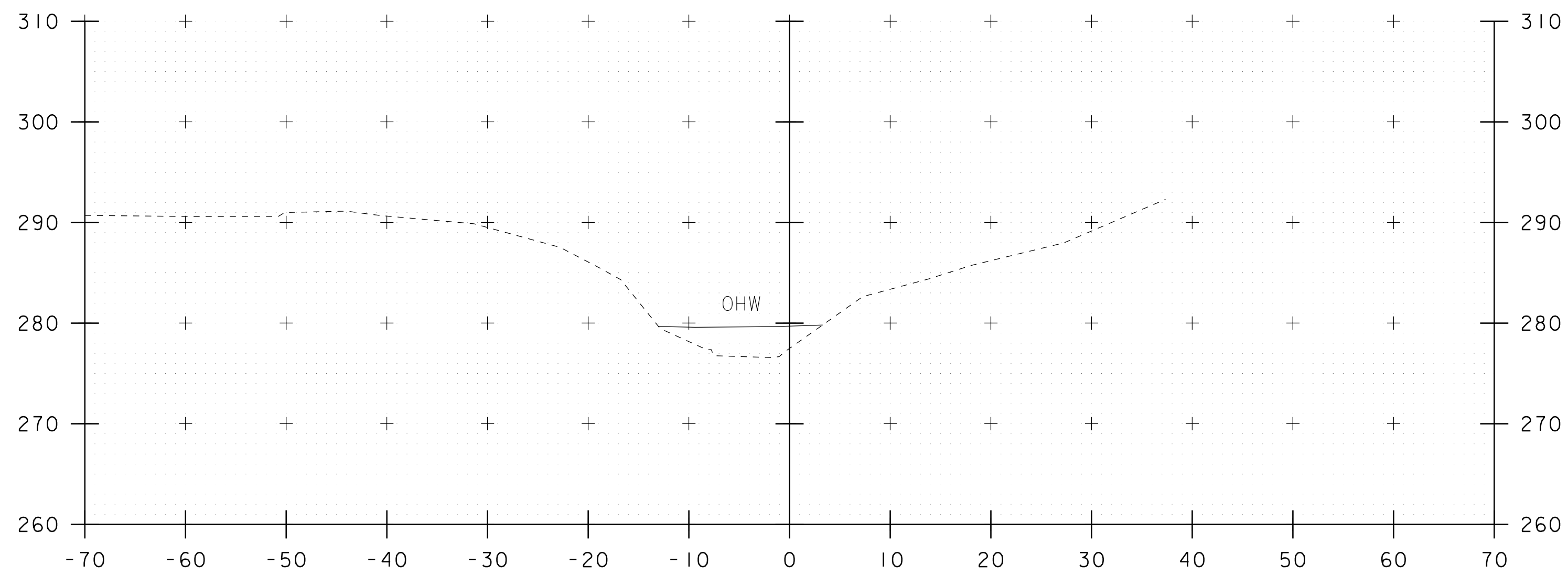

52+75

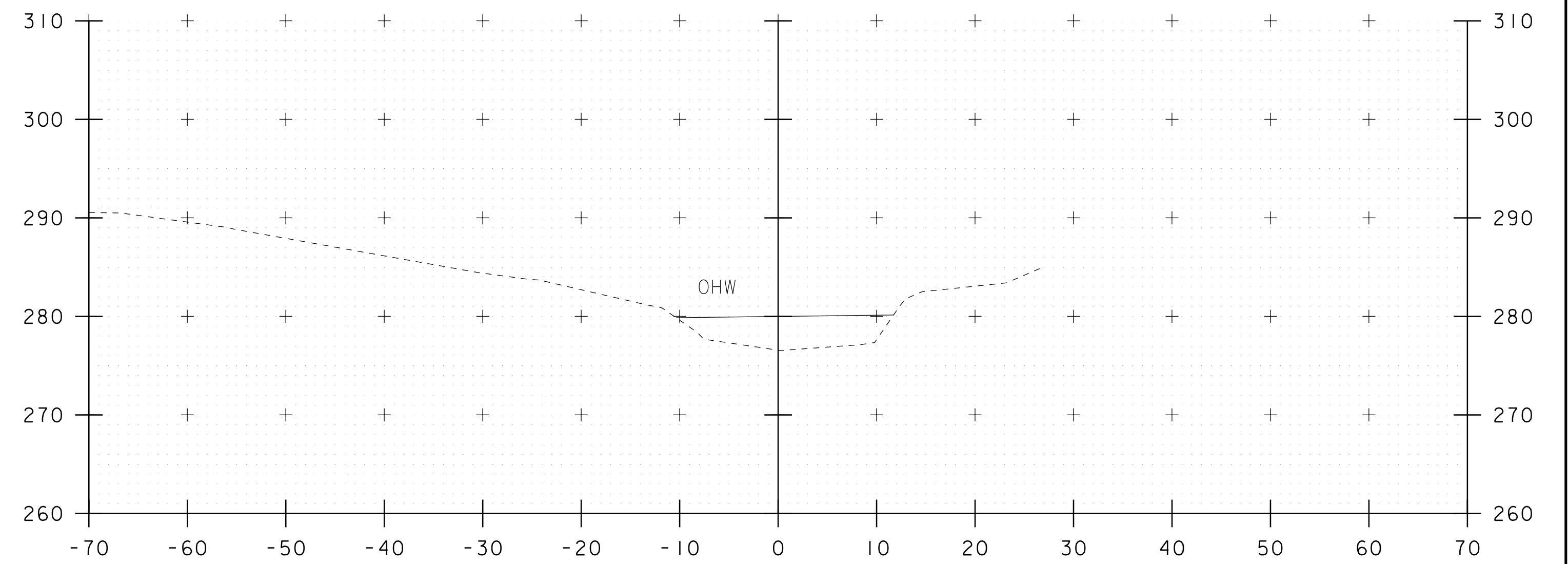

53+25

STA. 52+75 TO STA. 53+50

<b>PROJECT NAME:</b> ESSEX		<b>PLOT DATE:</b> 07-AUG-2017	
<b>PROJECT NUMBER:</b> BF 5400(9)		<b>DRAWN BY:</b> G. DARGAN	
<b>FILE NAME:</b> sl3d654xs.dgn	<b>DESIGNED BY:</b> G. DARGAN	<b>CHECKED BY:</b> -----	<b>SHEET</b> 25 <b>OF</b> 27
<b>CHANNEL CROSS SECTIONS 4</b>			

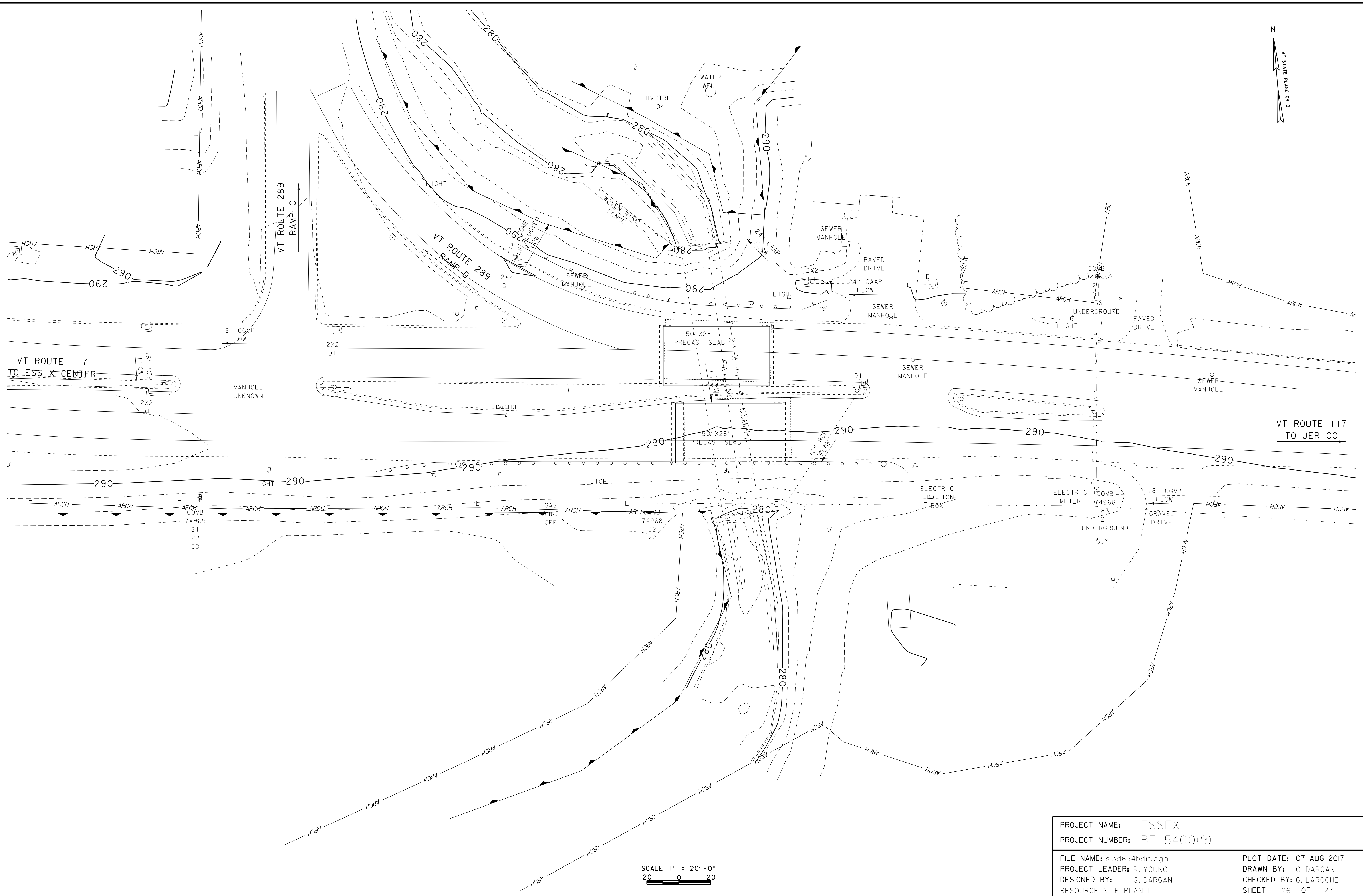

SCALE 1" = 20'-0"  
20 0 20

PROJECT NAME: ESSEX  
PROJECT NUMBER: BF 5400(9)

FILE NAME: s13d654bdr.dgn  
PROJECT LEADER: R. YOUNG  
DESIGNED BY: G. DARGAN  
RESOURCE SITE PLAN I

PLOT DATE: 07-AUG-2017  
DRAWN BY: G. DARGAN  
CHECKED BY: G. LAROCHE  
SHEET 26 OF 27

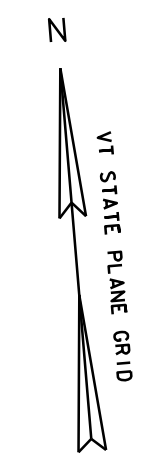

VT ROUTE 117  
TO JERICO

PROPOSED  
10" GAS LINE

COMB  
74965  
84  
20

SCALE 1" = 20' - 0"  
20 0 20

PROJECT NAME: ESSEX  
PROJECT NUMBER: BF 5400(9)

FILE NAME: sl3d654bdr.dgn  
PROJECT LEADER: R. YOUNG  
DESIGNED BY: G. DARGAN  
RESOURCE SITE PLAN 2

PLOT DATE: 07-AUG-2017  
DRAWN BY: G. DARGAN  
CHECKED BY: G. LAROCHE  
SHEET 27 OF 27